



16575169
Edition 1
June 2006

Electric Angle Wrench

QE6 Series

Maintenance Information



Save These Instructions

IR *Ingersoll Rand*

General Instructions:

- Refer to “Suggested Tools Parts List” for quick reference to the tools recommended for the following disassembly/assembly instructions.

WARNING

- Repairs should be made only by authorized trained personnel. Consult your nearest Ingersoll Rand Authorized Service Center.
- Disconnect the power cord from the receptacle before performing any maintenance on this or any other tool.
- Always use protective eyewear when performing maintenance on a tool or while operating a tool.
- Use of non-Ingersoll Rand parts or failure to follow Maintenance Instructions may create a risk of electric shock or injury.

Note: When reading instructions refer to exploded diagrams in Parts Information manual when applicable (see under related documentation for form numbers).

Lubrication

Whenever this product is disassembled, clean the parts and re-lubricate them as follows:

1. Using appropriate tool, loosen the Coupling Nut (75, 76, 85 or 86).

2. Unthread Coupling Nut from Motor Housing and remove Angle Assembly Attachment.
3. Slide Gear Case out of Motor Housing Assembly and disassemble Gear Case.
4. Clean and degrease all parts except for the First Stage Needle Bearings (46) and the Second Stage Spindle Assembly (50).
5. Wipe clean the First Stage Needle Bearings (46) and the Second Stage Spindle Assembly (50) with a clean, dry and lint-free rag.
6. Once cleaned, apply prescribed amounts of **Ingersoll Rand #170 Grease** as follows:
 - 2 to 3 cc to central area between gears of Spindle Assembly (50)
 - 1 to 2 cc to face of Gear Head and Spindle Assembly
 - 4 to 5 cc to Planet Gears, Pins and Bearings
 - Thin layer on Ring Gear teeth (42)

For Models with an Angle Assembly Attachment:

7. Using **Ingersoll Rand #67 Grease**, lubricate Angle Head through Grease Fitting.

For Models with an In-Line Attachment:

8. Using **Ingersoll Rand #67 Grease**, lubricate the Square Drive Spindle Bearings (72), the Drive Spindle (64) and the Disengaging Spring (68).

Disassembly

WARNING

- This procedure is to be performed by an authorized, trained repair person. To ensure proper functioning of the tool:
- When replacing the Motor Housing Assembly (1), always ensure that the Memory Chip (11), Communication Board (12), Gear Pack Assembly and Attachment are all assembled as a set with the new Motor Housing Assembly.

CAUTION

- When replacing an Attachment, always use the Angle Assembly Attachment designed for that model. Never replace an Angle Assembly Attachment with an In-Line Attachment.
- When replacing a Gear Pack Assembly, always use the Assembly designed for that model.

General Instructions for Disassembly:

1. Do not disassemble the tool any further than necessary to replace or repair damaged parts.
2. To protect part surfaces and to prevent distortion of Housings and threaded joints, use care when grasping the tool.
3. Avoid clamping non-metal surfaces, unless directed otherwise.
4. Do not remove any press fit part or any part of an assembly unless its removal is necessary for repair or replacement.

Grips

For Models with Levers:

1. Using an appropriate tool (eg, a driver or socket) loosen Cap Screws (30) from lever (28 or 29) and remove lever from Handle Grip (23, 26).
2. Slide Handle Grip off Motor House Assembly.

For Models with Gear Case Sleeves:

1. (Note: remove all attachments first.) If desired, separate Gear Case Sleeve (5) from Motor Housing Assembly.

Attachments

WARNING

- Do not separate Gear Case from Motor Housing, as this will likely destroy the Transducer wire.
- NEVER grasp the tool in a vise, as this will likely result in damage to the tool causing wire leads to malfunction, which increases the risk of electric shock.

CAUTION

- When installing or removing a Coupling Nut, ALWAYS hold the tool by the Spanner holes or flats as provided on the Assembly Housing.

Angle Assembly Attachments

1. Looking down hole of the Spindle's square socket, locate Retaining Pin (83) and Retaining Spring (82).
2. If necessary, using a pointed metal probe to pull retaining Spring out of Spindle cavity.
3. Also, if necessary, remove Pin from Spindle.
4. Using Spanner Wrench #GEA40-478 (or other appropriate wrench), grasp the Spanner holes (or flats) of the Coupling Nut (85 or 86).
5. Holding firmly onto tool with the Spanner Holes in the Gear Case, unscrew Coupling Nut and pull the Angle Assembly Attachment (81) out of Motor Housing Assembly (01, 02, 03 or 04).
6. If needed, pull Teflon Spacer (84) off Angle Assembly Attachment.
7. If necessary, remove Coupling Nut Retainer (87) using an appropriate tool.
8. Remove Coupling Nut.

In-Line Attachments

1. Looking down hole of Spindle's square socket, locate Retaining Pin (66) and Retaining Spring (65).
2. If necessary, using a pointed metal probe to pull retaining Spring out of Spindle cavity.
3. Also if necessary, remove Pin from Square Drive Spindle (64).
4. Using Spanner Wrench #GEA40-478 (or other appropriate wrench), grasp the Spanner holes (or flats) of the Coupling Nut (85 or 86).
5. Holding firmly onto tool with the Spanner Holes in the Gear Case, unscrew Coupling Nut and pull the In-Line Attachment (81) out of Motor Housing Assembly (01, 03 or 04).
6. If needed, pull Teflon Spacer (74) off Attachment.
7. If desired, remove Coupling Nut Retainer (77) using the appropriate tool.

Note: In the following step, the Bearing Cap (73) has a left-hand thread.

8. Using an adjustable Pin Wrench, unscrew Bearing Cap (73).
9. Pull the Drive Spindle Assembly (69) out of Housing Assembly (61).
10. If necessary, using a bearing puller tool, press the Rear Spindle Bearing (72) off the Drive Spindle Assembly (69). Then remove the Retaining Ring (71), and Washer (70).
11. Now tilt Spindle Housing, causing the Disengaging Spring (68), Coupler (67), Square Drive Spindle (64), and Washers (62) and (63) to slide out.

Motor Housing Disassembly

WARNING

- **In the course of disassembling or assembling this product, beware of any attempt to separate the gear case from or tighten the gear case to the motor housing assembly. Destruction of the transducer wire will result.**
1. Using appropriate tool, remove Retaining Ring (54), Retainer Washer (53), Wave Spring (52) and Grease Seal (51).
 2. Remove Gear Pack from Motor Housing Assembly.
 3. Remove Retaining Ring (43) from Ring Gear (42).
 4. From either end, slide internal components out of Ring Gear.
 5. Separate Spindle Assembly (50) from the Gear Head Assembly (45).
 6. Separate the Planet Gears (47), Needle Bearings (46), Spacers (44) and (49), and, when applicable, Sun Gear (48).

WARNING

- **This procedure is to be done by an authorized, trained repair person. To ensure proper functioning of the tool:**

When replacing the Motor Housing Assembly (11), always ensure that the Memory Chip (12), Communication Board, Gear Pack Assembly and Attachment are all assembled as a set with the new Motor Housing Assembly.

Disassembly of External Components

1. Dislodge O-rings (20) and remove Memory Chip (12) from assembly.
2. Remove Trigger mechanism (09) from Motor Housing assembly.
3. Remove Spring (10) from Trigger mechanism.
4. Slide Reverse Ring (22) away from Housing, being careful not to lose Detent Ball (07) or Springs (08 and 21).
5. Remove Retaining Ring (19) from behind Label Cover Lens (18).

6. In a sliding motion, pull Warning Label (17) and Label Cover Lens (18) off end of Motor Housing Assembly.
7. Slide Housing Cover (15) off Motor Housing Assembly.
8. Remove O-ring (14) located at front of Housing Cover.

Communication Board (Close-Up)

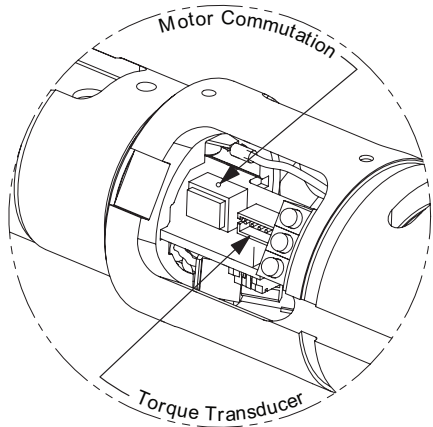

Torque and Motor Connector(s)

(Dwg.TP2102a_C)

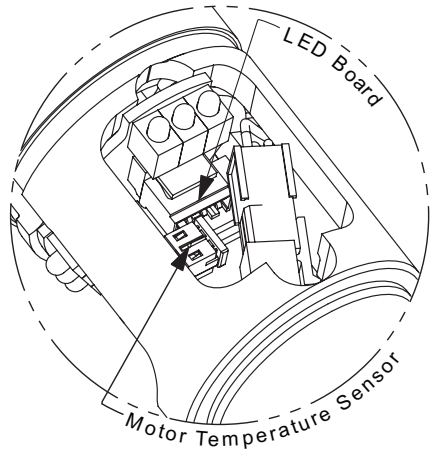

LEDs and Temperature Connector(s)

(Dwg. TP2102b_C)

Disassembly of Internal Components

1. Remove Retainer (13) used to retain Communication Board (12), located at rear end of Motor Housing Assembly in Connector cavity.
2. In large cavity area(s) of Motor Housing, disconnect the Motor Phase connector. (Refer to TP2102b)
3. Disconnect the Motor temperature-sensor connector from the Communication Board. (Refer to TP2102b)

4. Disconnect the Motor Commutation connector from the Communication Board. (Refer to TP2102a)
5. Disconnect the Torque Transducer connector from the Communication Board. (Refer to TP2102a)
6. Disengage female socket located on front end of Communication Board, from male connector located at center of LED Board (06) by gently sliding board from Motor Housing Assembly.
7. Remove LED Board from Motor Housing Assembly. (Refer to TP2102b)

Transducer Removal

1. Locate the cavity found at end of long axial groove running along the outer surface of the Motor Housing Assembly.
2. Make sure the Transducer connector is disconnected from the Communication Board.
3. Gently pull Transducer out of the Motor Housing Assembly, feeding the Transducer wire through the cavity in the Motor Housing Assembly from step 1.
4. Carefully push Transducer's connector through the cavity and remove Transducer assembly from Motor Housing Assembly.

Assembly

Motor Housing Assembly

General Instructions:

1. To protect the part's surfaces and to prevent distortion of Housings and threaded joints, use care when grasping the tool.
2. Always press on the inner ring of a ball-type bearing when installing the bearing onto a shaft.
3. Always press on the outer ring of a ball-type bearing when pressing the bearing into a bearing recess.
4. Refer to the "Lubrication" section of this manual for instruction on how to properly grease this tool.

WARNING

- **This procedure is to be done by an authorized, trained repair person. To ensure proper functioning of the tool:**

When replacing the Motor Housing Assembly, always ensure that the Memory Chip, Communication Board, Gear Pack and Attachment are all assembled as a set with the new Motor Housing Assembly.

The QE6 Series Motor Housing Assembly consists of the following:

1. One (1) Motor Assembly
2. One (1) Gear Case
3. One (1) Pinion

Note: These Motor Housing Assembly models vary in their maximum torque and Gear Case configurations (flanged and non-flanged). Refer to Table 3 to order the correct sub-assembly for your particular model.

The following two diagrams, TP2099 & TP2100 depict two of four possible arrangements listed in 'Table 3'. Drawing TP2099 illustrates one of the 'non-flanged' arrangements listed in 'Table 3'; drawing TP2100 depicts a typical 'flanged' arrangement. Either assembly, 'flanged' or 'nonflanged', is available with any one of two possible Pinion types, as shown.

Table 3 - Motor Housing Assembly Used

Motor Housing Assembly Prefix	Non-Flanged	Flanged
QE6S()020 QE6S()030 QE6S()050 QE6A()030 QE6A()040 QE6A()080 QE6Z()020 QE6Z()030	GEA40-M53-7	GEF40-M53-7
QE6Z()050	GEA40-M53-7	GEF40-M53-7
QE6S()035 QE6A()050 QE6Z()035	GEA40-M53-11 GEA40-M53-11 GEA40-M53-11	GEF40-M53-11 GEF40-M53-11 GEF40-M53-11

Non-Flanged Assembly

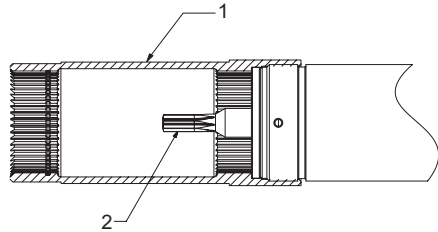

(Dwg. TP2099)

Flanged Gear Assembly

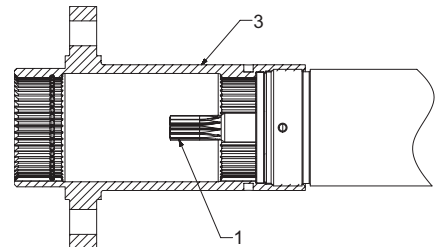

(Dwg. TP2100)

Internal Components

1. Insert the LED Board (6) through one of the Motor Housing Assembly's three large cavities and lay the three ledges of the LED Board (06) against the three edges of the Motor Housing Assembly (Refer to TP2102a) making sure that the motor commutation wires properly pass through the cutout in the LED board.
2. Using two of the three internal axial grooves of Motor Housing Assembly, slide Communication Board (12) into Motor Housing Assembly.
3. Press connector located on front end of Communication Board into socket located at center of LED Board.
4. Route Motor Commutation wiring to same side of Communication Board; snap connector into socket marked Motor. (Refer to TP2102a)
5. Route Motor Temperature Sensor Connector cable to opposite side of Communication Board; snap Motor Temperature-Sensor connector into the Motor Temperature-Sensor socket.
6. Through large cavities of Motor Housing Assembly, connect Motor Phase Female Connector to Male Connector of Motor.

7. Install Retainer (13) behind Communication Board in connector cavity in the end of the Motor Housing Assembly.

Communication Board (Close-Up)

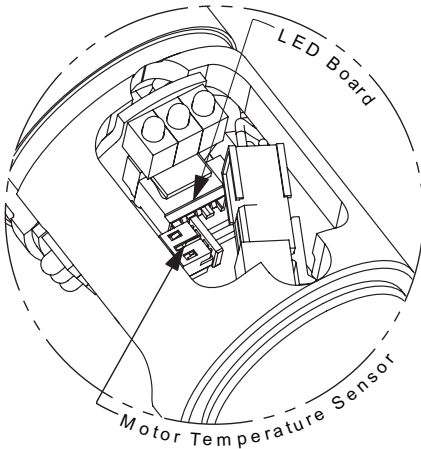

LEDs and Temperature Connector(s)

(Dwg. TP2102a_C)

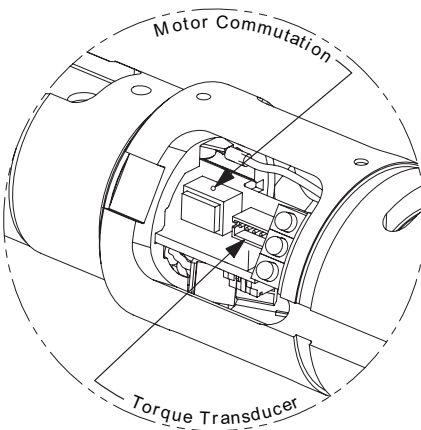

Torque and Motor Connector(s)

(Dwg. TP2102b_C)

Transducer Installation

1. Insert Transducer Assembly (41) into Gear Case of the Motor Housing Assembly, wire end first, guiding Transducer's connector into the cavity found at end of Motor Housing Assembly's long outer groove.
2. Carefully pull Transducer's connector and wiring through cavity of Motor Housing Assembly.
3. Engage Transducer's gear teeth to those of the front of Gear Case of the Motor Housing Assembly and continue

inserting Transducer assembly further into the Motor Housing while guiding the wire through the cavity.

4. Align and engage Transducer's gear teeth with second set of gear teeth located inside the Gear Case of the Motor Housing Assembly. Be certain that the Transducer wire exits the Transducer directly over the access cavity through which the wire was fed.
5. Continue inserting the Transducer Assembly until it is fully seated.
6. Snap Transducer's connector into Communication Board (12) socket marked Torque. (Refer to TP2102a)

External Components

1. Slide O-ring (14) into groove located at front end of Motor Housing Assembly.
2. Slide on Housing Cover (15), ensuring that Transducer and Motor wires are not disturbed.
3. Slide Warning Label into Label Cover Lens. Note Warning Label (17) and Label Cover Lens (18) slot and tab alignment features.
4. Slide Label Cover Lens and Warning label over Motor Housing Assembly grip area.
5. Install Retaining Ring (19) into groove behind Label Cover Lens.
6. Place Spring (21) into Reverse Ring (22).
7. Install and depress Ball (07) and Spring (08) and slide Reverse Ring onto Motor Housing Assembly.

When replacing the Motor Housing Assembly, always ensure that the Memory Chip, Communication Board, Gear Pack and Attachment are all assembled as a set with the new Motor Housing Assembly.

8. Install Memory chip (11) into grip with terminal aligned with O-ring groove.
9. Slide two O-rings (20) into groove to retain Memory chip.
10. Install Spring (10) on rearward post of Trigger and install Trigger into Motor Housing Assembly.
11. **For models with Extended Levers (29)**, install additional spring on Trigger's (09) auxiliary post.
12. Slide Handle Grip (23, 26) onto Motor Housing Assembly.
13. Apply a medium strength thread locker to Low Head Socket Cap Screw (27).
14. Install Low Head Socket Cap Screw through hole in Handle Grip into Motor Housing Assembly.
15. Torque Low Head Socket Cap Screw to 10 to 15 lbf • in (1.1 to 1.7 Nm).
16. **For models with Levers:**
 - a Place Lever (28 or 29) in position against Handle Grip and install lever Socket Cap Screws (30).
 - b Torque Socket Cap Screws (30) to 5 to 10 lbf • in (0.5 to 1.1 Nm).

WARNING

- The following procedures are to be performed by an authorized, trained repair person. To ensure proper functioning of the tool:
- In the course of disassembling or assembling this product, beware of any attempt to separate the gear case from or tighten the gear case to the motor housing assembly. Destruction of the transducer wire will result.

CAUTION

- When replacing an Attachment, always use the Angle Head Attachment designed for that model. Never replace an Angle Head Attachment with an In-Line Attachment.
- When replacing a Gear Pack Assembly, always use the Assembly designed for that model.

Gear Box - Assembly

1. Grease and install one Needle Bearing (46) into each of the three Planet Gears (47).
2. Slide one Gear/Bearing unit onto each of the three Planet Pins of the Gear Head Assembly (45).
3. For Models with Sun Gears, engage the teeth of the Sun gear (48) with those of the planets and press Sun Gear into Gear Head Assembly.
4. Apply Grease (**Ingersoll Rand #67**) to inside of Ring Gear (42).
5. Install Retaining Ring (43) taking care to align properly into groove of Ring Gear.
6. Install metal Spacer (44) inside Ring Gear, locating Spacer against Retaining Ring (43).
7. Apply grease to the teeth of the Planet gears and sun gear of the Gear Head Assembly as described in the lubrication section.
8. Aligning Planet gear teeth of the Gear Head assembly with gear teeth of Ring Gear, gently guide Gear Head Assembly (45) into open end of Ring Gear, locating Gear Head Assembly against Spacer (44).
9. Grease both sides of the spacer and place Spacer (49) on top of the Gear Head Assembly located inside Ring Gear.
10. Grease the planet gear teeth of the Spindle Assembly, as described in the lubrication section.
11. Align Pinion of Gear Head Assembly with Planet Gear teeth of Spindle Assembly (50) and the Planet gear teeth of the Spindle Assembly with those of the Ring Gear (42) and install Spindle Assembly against Spacer (49).
12. To assure free rotation of assembly, while holding Ring Gear steady, manually rotate the Spindle Assembly.

Gear Pack Installation

1. Insert the Gear pack into the Gear Case of the Motor Housing Assembly.
2. Engage Rotor Pinion with the Gear Head Assembly of the Gear Pack Assembly and gently guide teeth of Ring Gear onto teeth of Transducer.
3. Force rubber Grease Seal (51) into Gear Case of the Motor Housing so that it rests flat on top of Ring Gear.
4. Drop Wave Spring (52) on top of Grease Seal.
5. Lay Retaining Washer (53) on top of Wave Spring.
6. Using Snap Ring Pliers, install Retaining Ring (54) into Gear Case of the Motor Housing Assembly on top of retaining Washer until Retaining Ring rests inside groove.

Attachments

Angle Assembly Attachment

1. Visually check Housing for loose material fragments.
2. Install Socket Retaining Pin (83) into small hole on the one of the flat sides of square Spindle.
3. With Socket Retaining Pin (83) in place, locate the Pin's groove inside large end-hole of square Spindle.
4. Position Socket Retaining Spring inside large hole of square Spindle such that the free ends of the Socket Retaining Spring are faced away from the hole and the closed side of the spring will straddle the Socket Retaining Pin (83).
5. Holding the Socket Retaining Pin steady, push Spring down hole of square Spindle until the Socket Retaining Spring's wire engages Socket Retaining Pin.
6. Socket Retaining Pin is properly installed when Socket Retaining Spring snaps into place.
7. Spin square Spindle by hand to check freedom of movement.
8. Slide Teflon Spacer (84) over input shaft of Angle Assembly Attachment.
9. Slide Coupling Nut (85 or 86) over Angle Assembly Attachment.
10. Using an appropriate tool, install Retainer (87) on assembly. Take care to seat Retainer Ring in groove.
11. Spin Coupling by hand to check freedom of movement.

12. **For Models with Gear Case Sleeves:** Slide Gear Case Sleeve (5) over Gear Case of Motor Housing Assembly. (Slightly lubricating inside of sleeve with dish soap will help ease the installation process)
13. Position the Angle Assembly Attachment to desired orientation.
14. Engage Angle Assembly Attachment's Pinion into spline of Spindle Assembly (50), then engage the spline on the Angle Assembly Attachment with the Gear Case of the Motor Housing Assembly.
15. Thread Coupling Nut (85 or 86) onto Gear Case of Motor Housing Assembly.
16. While holding the tool using a Spanner wrench on the Spanner holes of the Gear Case, torque Coupling Nut to between 45 to 50 lbf • ft (61 to 68 Nm).

In-Line Attachment - Assembly

1. Install Socket Retaining Pin (66) into small hole provided in one of the flat walls of the square Spindle.
2. With Pin in place, locate Pin's groove inside large end-hole of square Spindle.
3. Position Spring inside large hole of square Spindle such that the free ends of the Socket Retaining Spring are faced away from the hole and the closed side of the spring straddles the Socket Retaining Pin (66).
4. Holding the Socket Retaining Pin steady, push Spring down hole of square Spindle until the Socket Retaining Spring's wire engages Socket Retaining Pin.
5. Socket Retaining Pin is properly installed when Socket Retaining Spring snaps into place.
6. Spin Spindle by hand to check freedom of movement.
7. Lubricate the bearings of the Housing Assembly (61) with **Ingersoll Rand # 67 Grease**.
8. Slide Washer (62) and Washer (63) onto Square Drive Spindle (64) and insert Square Drive Spindle (64) into Housing Assembly (61).
9. Align the Coupler (67) to slide over splines of Square Drive Spindle (64).
10. Slide Coupler into position in Housing Assembly (61).
11. Slide Washer (70) on the Drive Spindle Assembly (69).
12. Use snap-ring Pliers to install the Retaining Ring (71) on top of the Washer.
13. Press on Rear Spindle Bearing (72) to Drive Spindle Assembly (69).
14. Place Disengaging Spring (68) over Drive Spindle Assembly.
15. Align the Drive Spindle Assembly with spline of Coupler and insert Drive Spindle assembly into Housing assembly (61).
16. Apply one drop of Perma-Lok MM-115 to threads of Bearing Cap (73).
17. Carefully grasp the Housing Assembly.

Note: In the following step, the Bearing Cap (73) has a left-hand thread

18. Using the appropriate tool, tighten Bearing Cap (73) to between 45 to 50 lbf • ft (61 to 68 Nm) of torque.
19. Slide Teflon Spacer (74) over In-Line Attachment's input spindle.
20. Slide Coupling Nut (75 or 76) over Housing Assembly (61).
21. Using an appropriate tool, install Retainer (77) onto spline of Housing Assembly until seated into groove.
22. Spin Coupling by hand to check freedom of movement.

In-Line Attachment - Installation

1. **For Models with Gear Case Sleeves:** From threaded end of Motor Housing slide (rubber) Gear case Sleeve (5) over Housing. (Slightly lubricating Grip will help ease the installation process.)
2. Assure presence of Teflon Spacer on Pinion of Attachment.
3. Position the In-Line Attachment appropriately.
4. Engage the spline on the input spindle of the In-Line Attachment with the matching internal spline of the Spindle Assembly (50), then engage the spline on the Housing assembly with the Gear Case of the Motor Housing Assembly and thread the Coupling Nut onto the Motor Housing.
5. While holding the tool using a Spanner wrench on the Spanner holes of the Gear Case, torque Coupling Nut to between 45 to 50 lbf • ft (61 to 68 Nm).

QE6 Series Wiring (Cable) Chart

Connector Pin	Wire Color (Cable)	Logic	Connector Pin
A	Red	VCC	13
B	Black	COM	14
C	Gray	Spare 1	12
D	Pink	Spare 2	27
E	Brown	Spare 4	15
F	Yellow	Sine	21
G	Orange	Cosine	28
H	Violet	Spare 3	7
J	Green	Ground Sense	20
K	Blue	RX+	5
L	Blue/White	RX-	6
M	White	TX-	8
N	White/Blue	TX+	9
U	Red	Motor Phase B	23
V	Black	Motor Phase C	34
W	White	Motor Phase A	36
X	Green/Yellow	Ground	25
-----	-----	TX Shield	1
-----	-----	RX Shield	4
-----	-----	Hall Shield	22
-----	-----	Motor Shield	16

Parts and Maintenance

The use of other than genuine Ingersoll Rand replacement parts may result in safety hazards, decreased motor performance, and increased maintenance, and may invalidate all warranties.

Ingersoll Rand is not responsible for customer modification of motors for applications on which Ingersoll Rand was not consulted.

Repairs should be made only by authorized trained personnel. Consult your nearest Ingersoll Rand Authorized Service center.

When the life of the motor has expired, it is recommended that the motor be disassembled, degreased and parts be separated by material so that they can be recycled.

Refer all communications to the nearest Ingersoll Rand Office or Distributor.

Related Documentation

For additional information refer to:
 Safety Information Manual form 16573685.
 Product Information Manual form 16576951.
 Parts Information Manual form 16574469.

Manuals can be downloaded from www.irtools.com.

www.irtools.com

© 2006 Ingersoll Rand Company

