



16575177
Edition 1
June 2006

Electric Angle Wrench

QE8 Series

Maintenance Information



Save These Instructions

 **Ingersoll Rand**

General Instructions:

- Refer to “Suggested Tools Parts List” for quick reference to the tools recommended for the following disassembly/assembly instructions.

WARNING

- Repairs should be made only by authorized trained personnel. Consult your nearest Ingersoll Rand Authorized Service Center.
- Disconnect the power cord from the receptacle before performing any maintenance on this or any other tool.
- Always use protective eyewear when performing maintenance on a tool or while operating a tool.
- Use of non-Ingersoll Rand parts or failure to follow Maintenance Instructions may create a risk of electric shock or injury.

Note: When reading instructions refer to exploded diagrams in Parts Information manual when applicable (see under related documentation for form numbers).

Lubrication

Whenever this product is disassembled, clean the parts and re-lubricate them as follows:

1. Using appropriate tool, loosen the Attachment Coupling Nut (75 or 76).

2. Unthread Coupling Nut from Gear Case Assembly and remove Angle Head Attachment.
3. Using appropriate tool, loosen the Gear Case Coupling Nut (40).
4. Unthread Coupling Nut from Motor Housing Assembly (1) and remove Gear Case Assembly.
5. Disassemble Gear Case.
6. Clean and degrease all parts except for the 1st Stage Spindle Assembly (36) and the 2nd Stage Spindle Assembly (38).
7. Wipe clean the Spindle Assemblies with a clean, dry and lint-free rag.
8. Once cleaned, apply prescribed amounts of **Ingersoll Rand #67 Grease** as follows:
 - 2 to 3 cc to central area between gears of 1st Stage Spindle Assembly (36)
 - 2 to 3 cc to central area between gears of 2nd Stage Spindle Assembly (38)
 - Thin layer on Ring Gear teeth (37)
9. **For Models with an Angle Head Attachment:** Using **Ingersoll Rand #67 Grease**, lubricate Angle Head (81) through Grease Fitting.
10. **For Models with an In-Line Attachment:** Using **Ingersoll Rand #67 Grease**, lubricate the Square Drive Spindle Bearings, the Drive Spindle (64) and the Disengaging Spring (68).

Disassembly

WARNING

- This procedure is to be performed by an authorized, trained repair person. To ensure proper functioning of the tool:
- When replacing the Motor Housing Assembly (1), always ensure that the Memory Chip (7), Communication Board (8), Gear Case Assembly, and Attachment are all assembled as a set with the new Motor Housing Assembly.

CAUTION

- When replacing an Attachment, always use the Angle Head Attachment designed for that model. Never replace an Angle Head Attachment with an In-Line Attachment.
- When replacing a Gear Case Assembly, always use the Assembly designed for that model.

General Instructions for Disassembly:

1. Do not disassemble the tool any further than necessary to replace or repair damaged parts.
2. To protect part surfaces and to prevent distortion of Housings and threaded joints, use care when grasping the tool.
3. Avoid clamping non-metal surfaces, unless directed otherwise.
4. Do not remove any press fit part or any part of an assembly unless its removal is necessary for repair or replacement.

Attachments

WARNING

- NEVER grasp the tool in a vise, as this will likely result in damage to the tool causing wire leads to malfunction, which increases the risk of electric shock.

CAUTION

- When installing or removing a Coupling Nut, ALWAYS hold the tool by the Spanner holes or flats as provided on the Assembly Housing.

Angle Head Attachments

1. Looking down hole of the Spindle's square socket, locate Retaining Pin (83) and Retaining Spring (82).
2. If necessary, use a pointed metal probe to pull Retaining Spring out of Spindle cavity.
3. Also, if necessary, remove Pin from Spindle.
4. Using Spanner Wrench #GEA40-478 (or other appropriate wrench), grasp the Spanner holes (or flats) of the Coupling Nut (75 or 76).
5. Holding firmly onto tool with the wrench flats of the Gear Case (41), unscrew Coupling Nut and pull the Angle Head Attachment (81) out of the Gear Case.
6. If necessary, remove Coupling Nut Retainer (77) using an appropriate tool.

In-Line Attachments - Disassembly

1. Looking down hole of Spindle's square socket, locate Retaining Pin (66) and Retaining Spring (65).
2. If necessary, use a pointed metal probe to pull retaining Spring out of Spindle cavity.
3. Also if necessary, remove Pin from Square Drive Spindle (64).
4. Using Spanner Wrench #GEA40-478 (or other appropriate wrench), grasp the Spanner holes (or flats) of the Coupling Nut (75 or 76).
5. Holding firmly onto tool with the wrench flats of the Gear Case, unscrew Coupling Nut and pull the In-Line Attachment out of the Gear Case (41).
6. If desired, remove Coupling Nut Retainer (77) using the appropriate tool.

Note: In the following step, the Bearing Cap (73) has a left-hand thread.

7. Using an adjustable Pin Wrench, unscrew Bearing Cap (73).
8. Pull the Drive Spindle Assembly (69) out of Housing Assembly (61).
9. If necessary, using a bearing puller tool, press the Rear Spindle Bearing (72) off the Drive Spindle Assembly (69). Then remove the Retaining Ring (71), and Washer (70).
10. Now tilt Spindle Housing, causing the Disengaging Spring (68), Coupler (67), Square Drive Spindle (64), and Washers (62) and (63) to slide out.

Motor Housing Disassembly

Gear Case - Disassembly

1. Carefully engage spanner holes on the Gear Case Coupling Nut (40) with the appropriate tool and loosen the Coupling Nut while gripping the wrench flats of the Gear Case (41) with the appropriate wrench.
2. Unthread the Coupling Nut (40) from the Motor Housing Assembly (1) and pull the Gear Case Assembly off the Motor Housing Assembly.
3. Remove the Pinion Coupler Assembly (34) from the Motor Housing Assembly.
4. **For Non-Flanged Models:** If the Coupling Nut requires replacement, slide the Coupling Nut off the Gear Case Assembly.
5. **For Flanged Models:**
 - a If the Coupling Nut requires replacement, spread the ends of the Retaining Ring (39) and remove it from the Gear Case Assembly.
 - b Slide Coupling Nut off the Gear Case Assembly.
6. Work a pointed tool under the Ring Gear Retainer (33) and spiral it out of the Gear Case (41).
7. Tilt the Gear Case Assembly so that the Ring Gear (37) and 1st Stage Spindle Assembly (36) slide out of the Gear Case Assembly.
8. With the motor end of the Gear Case Assembly standing on the table of an Arbor press, carefully press the 2nd Stage Spindle Assembly (38) out of the Bearing (42) while lightly supporting the Spindle Assembly from beneath to avoid breakage.
9. Using internal snap ring pliers, remove the Retaining Ring (43) from the threaded end of the Gear Case (41).
10. Remove Bearing (42) from the Gear Case.

⚠ WARNING

- **This procedure is to be done by an authorized, trained repair person. To ensure proper functioning of the tool:**

When replacing the Motor Housing Assembly (1), always ensure that the Memory Chip (7), Communication Board (8), Gear Case Assembly, and Attachment are all assembled as a set with the new Motor Housing Assembly.

Grips

1. For models with levers, use the appropriate hex key to loosen Cap Screws (23) from lever (24 or 25) and remove lever from Handle Grip (19 or 20).
2. Use the appropriate hex key to loosen the Cap Screw (22) from Handle Grip (18, 19, 20 or 21).
3. Slide Handle Grip off of Motor House Assembly (1).

Disassembly of External Components

1. Dislodge O-rings (15) and remove Memory Chip (7) from assembly.
2. Remove Trigger mechanism (5) from Motor Housing Assembly.
3. Remove Spring (6) from Trigger mechanism.
4. Slide Reverse Ring (17) away from Motor Housing Assembly, being careful not to lose the Detent Ball (3) or Springs (4) and (16).

5. Remove Retaining Ring (14) from behind Label Cover Lens (13).
6. In a sliding motion, pull Warning Label (12) and Label Cover Lens (13) off end of Motor Housing Assembly.
7. Slide Housing Cover (11) off Motor Housing Assembly.
8. Remove O-ring (10) located at front of Housing Cover.

Communication Board

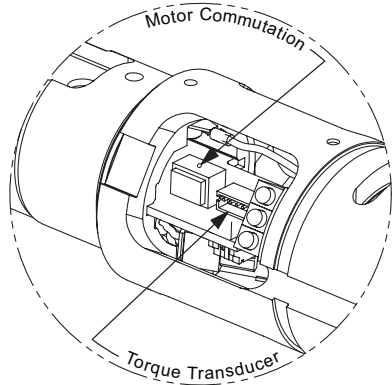

Torque and Motor Connector(s)

(Dwg. TP2162a)

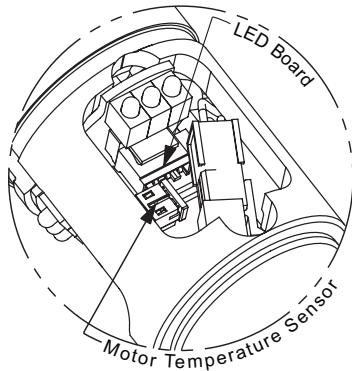

LEDs and Temperature Connector(s)

(Dwg. TP2162b)

Disassembly of Internal Components

1. Remove Retainer (9) used to retain Communication Board (8), located at rear end of Motor Housing Assembly in Connector cavity.
2. In large cavity area(s) of Motor Housing, disconnect the Motor Phase connector. (Refer to TP2162b)
3. Disconnect the Motor temperature-sensor connector from the Communication Board. (Refer to TP2162b)
4. Disconnect the Motor Commutation connector from the Communication Board. (Refer to TP2162a)
5. Disconnect the Torque Transducer connector from the Communication Board. (Refer to TP2162a)
6. Disengage female socket located on front end of Communication Board, from male connector located at center of LED Board (2) by gently sliding board from Motor Housing Assembly.

7. Remove LED Board from Motor Housing Assembly. (Refer to TP2162b)

Transducer Removal

1. Locate the cavity found at end of long axial groove running along the outer surface of the Motor Housing Assembly.
2. Make sure the Transducer connector is disconnected from the Communication Board.
3. Gently pull Transducer (31) out of the Motor Housing Assembly, while feeding the Transducer wire and connector through the cavity in the Motor Housing Assembly.
4. Carefully push Transducer's connector through the cavity of the Motor Housing Assembly.

Assembly

Motor Housing Assembly

General Instructions

1. To protect the part's surfaces and to prevent distortion of Housings and threaded joints, use care when grasping the tool.
2. Always press on the inner ring of a ball-type bearing when installing the bearing onto a shaft.
3. Always press on the outer ring of a ball-type bearing when pressing the bearing into a bearing recess.
4. Refer to the "Lubrication" section of this manual for instruction on how to properly grease this tool.



WARNING

- **This procedure is to be done by an authorized, trained repair person. To ensure proper functioning of the tool:**

When replacing the Motor Housing Assembly (1), always ensure that the Memory Chip (7), Communication Board (8), Gear Case Assembly, and Attachment are all assembled as a set with the new Motor Housing Assembly.

Internal Components

1. Insert the LED Board (2) through one of the Motor Housing Assembly's three large cavities and lay the three tabs of the LED Board against the three ledges of the Motor Housing Assembly (Refer to TP2162a) making sure that the motor commutation wires properly pass through the cutout in the LED board.
2. Using two of the three internal axial grooves located in the connector end of the Motor Housing Assembly, slide Communication Board (8) into Motor Housing Assembly.
3. Press connector located on front end of Communication Board into socket located at center of LED Board.
4. Route Motor Commutation wiring to same side of Communication Board; snap connector into socket marked Motor. (Refer to TP2162a)
5. Route Motor Temperature Sensor Connector cable to opposite side of Communication Board; snap Motor Temperature-Sensor connector into the Mot or Temperature-Sensor socket. (Refer to TP2162b)
6. Through large cavities of Motor Housing Assembly, connect Motor Phase Female Connector to Male Connector of Motor.
7. Install Retainer (9) behind Communication Board in connector cavity in the end of the Motor Housing Assembly.

Communication Board (Close-Up)

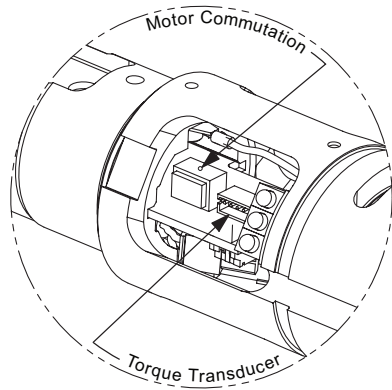

Torque and Motor Connector(s)

(Dwg. TP2162a)

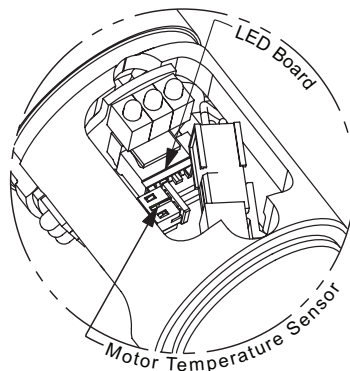

LEDs and Temperature Connector(s)

(Dwg. TP2162b)

Transducer Installation

1. Insert Transducer Assembly (31) into the Motor Housing Assembly, wire end first, guiding Transducer's connector out through the cavity found at end of Motor Housing Assembly's long outer groove.
2. Carefully pull Transducer's connector and wiring through cavity of Motor Housing Assembly.
3. Align and engage Transducer's gear teeth with the gear teeth located inside the end of the Motor Housing Assembly. Be certain that the Transducer wire exits the Transducer directly over the access cavity through which the wire was fed.
4. Continue inserting the Transducer assembly until it is fully seated.
5. Snap Transducer's connector into Communication Board (8) socket marked Torque. (Refer to TP2162a)

External Components

1. Slide O-ring (10) into groove located at front end of Motor Housing Assembly.
2. Slide on Housing Cover (11), ensuring that Transducer and Motor wires are not disturbed.
3. Slide Warning Label (12) into Label Cover Lens (13). Note Warning Label and Label Cover Lens slot and tab alignment features.
4. Slide Label Cover Lens and Warning Label over Motor Housing Assembly grip area. Orient tabs of Label Cover Lens with mating slots in Motor Housing Assembly, and slide together.
5. Install Retaining Ring (14) into groove behind Label Cover Lens.
6. Place Spring (16) into Reverse Ring (17).
7. Install and depress Ball (3) and Spring (4) and then slide Reverse Ring onto Motor Housing Assembly.

When replacing the Motor Housing Assembly (1), always ensure that the Memory Chip (7), Communication Board (8), Gear Case Assembly, and Attachment are all assembled as a set with the new Motor Housing Assembly.

8. Install Memory chip (7) into Housing with terminals aligned with O-ring groove.
9. Slide two O-rings (15) into groove to retain Memory chip.
10. Install Spring (6) on post in middle of Trigger (5) and install Trigger into Motor Housing Assembly.
11. **For models with Extended Lever (25)**, install an additional spring on Trigger's auxiliary post.
12. Slide Handle Grip (18, 19, 20, or 21) onto Motor Housing Assembly.
13. Apply a medium strength thread locker to Low Head Socket Cap Screw (22).
14. Install Low Head Socket Cap Screw into Motor Housing Assembly.
15. Torque Socket Cap Screw to 10 to 15 lbf • in (1.1 to 1.7 Nm).
16. **For models with Levers:**
 - a Place Lever (24 or 25) in position against Handle Grip and install lever Socket Cap Screws (23).
 - b Torque Socket Cap Screw (23) to 5 to 10 lbf • in (0.5 to 1.1 Nm).



WARNING

- **This procedure is to be performed by an authorized, trained repair person. To ensure proper functioning of the tool:**
- **In the course of disassembling or assembling this product, beware of any attempt to separate the gear case from or tighten the gear case to the motor housing assembly. Destruction of the transducer wire will result.**



CAUTION

- **When replacing an Attachment, always use the Angle Head Attachment designed for that model. Never replace an Angle Head Attachment with an In-Line Attachment.**
- **When replacing a Gear Case Assembly, always use the Assembly designed for that model.**

Gear Case - Assembly

1. Ensure that all the gears are free of debris.
2. Apply 2-3 cc of IR #67 grease to the central area between the gears and the surface of the gear teeth of the 1st Stage Spindle Assembly (36) and the 2nd Stage Spindle Assembly (38).
3. Insert Bearing (42) into threaded end of Gear Case (41) and push it in until it seats against the shoulder in the Gear Case.
4. Assemble the Retaining Ring (43) into the groove directly in front of the Bearing with internal snap ring pliers.
5. Support the Gear Case Assembly, threaded end down, on the inner race of Bearing (42).
6. Position the 2nd Stage Spindle Assembly (38) on the inner race of the Bearing (42) inside the Gear Case with the splined end of the Spindle Assembly facing the Bearing.
7. With an appropriate tool, press the 2nd Stage Spindle Assembly into Bearing (42) until the Spindle Assembly seats against the inner race of the Bearing.
8. Coat the inside and outside surfaces of the Ring Gear (37) with IR #67 grease.
9. Insert the Ring Gear into the Gear Case with the end of the Ring Gear having an internal groove towards the motor.
10. Align the Ring Gear teeth with those of the planets in the 2nd Stage Spindle Assembly and slide the Ring Gear into the Gear Case until it stops against the shoulder inside the Gear Case.
11. Install the Retainer (33) into the groove inside the motor end of the Gear Case to secure the Ring Gear.
12. Insert the 1st Stage Spindle Assembly (36) into the Gear Case and engage the teeth of the gear on the Gear Head Assembly with the planet gears of the 2nd Stage Spindle Assembly while aligning the planet gears of the Gear Head Assembly with the Ring Gear.
13. Install Retaining Ring (35) into groove in the end of the Ring gear.
14. **For Non-Flanged Gear Cases:** Slide the Coupling Nut (40) over the output end of the Gear Case Assembly.
15. **For Flanged Gear Cases:** Slide the Coupling Nut (40) on the input end of the Gear Case (41). Using the proper tool, slide the Retaining Ring (39) over the end and into the groove of the Gear Case.

Gear Case Assembly Installation

1. Install the Pinion Coupler Assembly (34) on the pinion of the motor.
2. Rotate the Gear Case Assembly to the desired orientation relative to the Motor Housing Assembly (1).
3. Insert the Motor Housing Assembly (1) into the Gear Case (41).
4. Align and engage the gear of the Pinion Coupler Assembly (34) with the Planets of the 1st Stage Gear Head Assembly (36) while engaging the Ring Gear (37) with the Transducer (31) teeth. It may be necessary to rotate the 2nd Stage Spindle Assembly (38) to aid in assembly.
5. Thread Coupling Nut (40) to the threads of the Motor Housing Assembly and torque to 50 - 60 ft•lbs (68 - 81 Nm).

Attachments

Angle Head Attachment - Assembly

1. Visually check Housing for loose material fragments.
2. Install Socket Retaining Pin (83) into small hole on one of the flat sides of square Spindle.
3. With Socket Retaining Pin (83) in place, locate the Pin's groove inside large end-hole of square Spindle.
4. Position Socket Retaining Spring (82) inside large hole of square Spindle such that the free ends of the Socket Retaining Spring are faced away from the hole and the closed side of the spring will straddle the Socket Retaining Pin.
5. Holding the Socket Retaining Pin steady, push Spring down hole of square Spindle until the Socket Retaining Spring's wire engages Socket Retaining Pin.
6. Socket Retaining Pin is properly installed when Socket Retaining Spring snaps into place.
7. Spin square Spindle by hand to check freedom of movement.
8. Slide Coupling Nut (75 or 76) over Angle Head Attachment.
9. Using an appropriate tool, install Retainer (77) on assembly. Take care to seat Retainer Ring in groove.
10. Spin Coupling Nut by hand to check freedom of movement.

In-Line Attachment - Assembly

1. Install Socket Retaining Pin (66) into small hole provided in one of the flat walls of the square Spindle.
2. With Pin in place, locate Pin's groove inside large end-hole of Square Drive Spindle (64).
3. Position Spring (65) inside large hole of Square Drive Spindle such that the free ends of the Socket Retaining Spring are faced away from the hole and the closed side of the Spring straddles the Socket Retaining Pin.
4. Holding the Socket Retaining Pin steady, push Spring down hole of square Spindle until the Socket Retaining Spring's wire engages Socket Retaining Pin.
5. Socket Retaining Pin is properly installed when Socket Retaining Spring snaps into place.
6. Lubricate the bearings of the Housing Assembly (61) with **Ingersoll Rand # 67 Grease**.
7. Slide Washer (62) and Washer (63) onto Square Drive Spindle and insert Square Drive Spindle (64) into Housing Assembly (61).
8. Align the Coupler (67) to slide over splines of Square Drive Spindle.
9. Slide Coupler into position in Housing Assembly (61).
10. Slide Washer (70) on the Drive Spindle Assembly (69).
11. Use snap-ring Pliers to install the Retaining Ring (71) on top of the Washer.
12. Press on Rear Spindle Bearing (72) to Drive Spindle Assembly (69).
13. Place Disengaging Spring (68) over Drive Spindle Assembly.
14. Align the Drive Spindle Assembly with spline of Coupler and insert Drive Spindle Assembly into Housing Assembly (61).
15. Apply one drop of Perma-Lok MM-115 to threads of Bearing Cap (73).
16. Carefully grasp the Housing Assembly.

Note: In the following step, the Bearing Cap (73) has a left-hand thread.

17. Using the appropriate tool, tighten Bearing Cap (73) to between 45 - 50 lbf • ft (61 - 68 Nm) of torque.
18. Slide Coupling Nut (75 or 76) over Housing Assembly (61).
19. Using an appropriate tool, install Retainer (77) onto spline of Housing Assembly until seated into groove.
20. Spin Coupling by hand to check freedom of movement.

In-Line Attachment - Installation

1. Position the In-Line Attachment appropriately.
2. Engage the spline on the input spindle of the In-Line Attachment with the matching internal spline of the 2nd Stage Spindle Assembly (38), and then engage the spline on the Housing Assembly (61) with that of the Gear Case (41).
3. Thread the Coupling Nut (75 or 76) onto the Gear Case.
4. While holding the tool using an appropriate wrench on the wrench flats of the Gear Case, torque Coupling Nut to between 45 - 50 lbf • ft (61 - 68 Nm).

QE8 Series Wiring (Cable) Chart			
Connector Pin	Wire Color (Cable)	Logic	Connector Pin
A	Red	VCC	13
B	Black	COM	14
C	Gray	Spare 1	12
D	Pink	Spare 2	27
E	Brown	Spare 4	15
F	Yellow	Sine	21
G	Orange	Cosine	28
H	Violet	Spare 3	7
J	Green	Ground Sense	20
K	Blue	RX+	5
L	Blue/White	RX-	6
M	White	TX-	8
N	White/Blue	TX+	9
U	Red	Motor Phase B	23
V	Black	Motor Phase C	34
W	White	Motor Phase A	36
X	Green/Yellow	Ground	25
---	---	TX Shield	1
---	---	RX Shield	4
---	---	Hall Shield	22
---	---	Motor Shield	16

Parts and Maintenance

The use of other than genuine Ingersoll Rand replacement parts may result in safety hazards, decreased motor performance, and increased maintenance, and may invalidate all warranties.

Ingersoll Rand is not responsible for customer modification of motors for applications on which Ingersoll Rand was not consulted.

Repairs should be made only by authorized trained personnel. Consult your nearest Ingersoll Rand Authorized Service center.

When the life of the motor has expired, it is recommended that the motor be disassembled, degreased and parts be separated by material so that they can be recycled.

Refer all communications to the nearest **Ingersoll Rand** Office or Distributor.

Related Documentation

For additional information refer to:

Safety Information Manual form 16573685.

Product Information Manual form 16576951.

Parts Information Manual form 16574477.

Manuals can be downloaded from www.irtools.com.

www.irtools.com

© 2006 Ingersoll Rand Company

