



45527793

Edition 1

July 2008

Electric Screwdrivers (Angle)

ES 115V AC Series

Maintenance Information



Save These Instructions

 **IR** Ingersoll Rand

WARNING

Always wear eye protection when operating or performing maintenance on this tool.

Always turn off the air supply and disconnect the air supply hose before installing, removing or adjusting any accessory on this tool or before performing any maintenance on this tool.

Note: When reading the instructions, refer to exploded diagrams in parts Information Manuals when applicable (see under Related Documentation for form numbers).

Lubrication

Whenever an Electric Screwdriver is disassembled for maintenance or repair, lubricate the following components in the recommended manner with **Ingersoll Rand** No. 67 Grease.

1. Inject a tiny amount of grease into the hole in the Pilot (66) for the Pilot Ball (67).
2. Wipe a film of grease on the tapered inner surface of the Slide Ring (70) and the Taper Ring Assembly (63).
3. Apply a moderate amount of grease to the outer surfaces of the Cam (54 or 56), the Cam Guide (60) and the Cam Guide Balls (61 and/or 62).
4. Wipe a thin coat of grease on each of the Spindle Gears (51).

CAUTION

Do not pack the gearing with grease. Excess grease may be pulled into the motor by the Armature Fan (42).

5. Wipe a very thin coating of grease onto Pilot Rod "H" (59).

WARNING

Pilot Rod "G" (43) must be totally free of grease. Grease on this Rod could cause electric shock.

Disassembly

Disassembly of Angle Attachment

For 3RL23 and 3RL25 Angle Attachments

1. Using the 141A12-26 Housing Cap Wrench, unscrew the Angle Housing Cap (113). This is a **left-hand thread**; rotate the Cap **clockwise** to loosen it.
2. Withdraw the Spindle Assembly (114 or 116) from the Angle Housing Assembly.

NOTICE

If more than one angle head is disassembled at a time, take care not to mix the Matched Gear Sets (103) from different Angle Attachments. These gear sets are specially matched and are available only as matched sets.

3. Inspect the Spindle Lower Bearing for looseness or roughness. If either of these conditions exists, remove the Bearing as follows:
 - a. Insert a 1/4" Allen Wrench in the Bit Holder Spindle Assembly or grasp the square drive or threaded end of the other Spindle Assembly in copper-covered vise jaws and unscrew the Bevel Gear Retainer Nut (111).
 - b. Lift off the Bevel Gear (103) from the Spindle.
 - c. Press the Spindle from the Spindle Lower Bearing.
4. For 3RL25 Angle Attachment, grasping the Spindle in copper-covered vise jaws and using a 1/16" (1.59 mm) punch, drive out the Socket Retainer (115) from the Washer on non-working side of the square on the Spindle.

NOTICE

Do not remove the Socket Retainer unless you have a new retainer ready to install. The retainer is destroyed during removal.

5. If the Spindle Upper Bearing appears rough or loose, press it from the Angle Head.

NOTICE

Do not remove the Spindle Upper Bearing unless you have a new bearing ready to install. This type of bearing is always damaged during removal.

6. Using snap ring pliers, remove the Thrust Bearing Retainer (104) and slide off the Rear Thrust Bearing Seat (105), and Bevel Pinion Thrust Bearing (106) from the pinion shaft.
7. Grasp the hex of the pinion shaft in copper-covered vise jaws and tap the rear face of the Angle Housing Assembly with a soft hammer to pull the Bevel Pinion Bearings (110).

NOTICE

Do not remove the pinion shaft and bearings unless you have two new bearings on hand.

After the Angle Attachment is disassembled, check all parts for damage or wear. If the gear teeth on either piece of the Matched Gear Set are worn or chipped, replace both parts. They are furnished in a matched set and must be replaced with a matched set.

8. Using a hooked tool, reach inside the Coupling Nut (108) and pull the Coupling Nut Retainer (109) from the Nut. Slide the Coupling Nut and Retainer off the motor end of the Angle Attachment.

For 3RL1A5 Angle Attachment

NOTICE

In order to prevent the loss of the twenty Steel Balls (120), place a container under the Angle Attachment before removing the Angle Housing Cap Assembly (113A).

1. Unscrew Angle Housing Cap Assembly. This is a **left-hand thread**; rotate the Cap clockwise to loosen it.
2. Remove Angle Housing Cap Seal (113B) from Angle Housing Cap.
3. Withdraw Spindle (103) and remove Shims (102A) from Angle Housing.

NOTICE

If more than one Angle Head is disassembled at a time, take care not to mix the Matched Bevel Gear Sets (103) from different Angle Attachments. These gear sets are especially matched and are available only as matched sets.

4. Remove the Ball Race (119) and Steel Balls from the Angle Housing Cap.
5. Put the Spindle in copper-covered vise jaws and holding a 1/16" (1.59 mm) punch against the Washer (103A), drive out the Socket Retainer Assembly.

NOTICE

Do not remove the Socket Retainer Assembly unless you have a new Socket Retainer ready to install. The retainer is destroyed during removal.

6. If the Upper Spindle Bearing (102) appears rough or loose, press it from the Spindle.
7. Using snap ring pliers, remove the Thrust Bearing Retainer (104) and slide off the Rear Thrust Bearing Seat Assembly (105) and Bevel Pinion Thrust Bearing (106).

- Grasp the hex of the Bevel Pinion Shaft in copper-covered vice jaws and tap the rear face of the Angle Housing with a soft hammer to pull the Bevel Pinion Bearing (110).

NOTICE

Do not remove the Bevel Pinion Shaft and Bevel Pinion Bearing unless you have a new Bearing on hand.

After the Angle Attachment is disassembled, check all parts for damage or wear. If the gear teeth on either piece of the Matched Bevel Gear Set are worn or chipped, replace both parts. They are furnished in a matched set and must be replaced in a matched set.

- Using a hooked tool, reach inside the Coupling Nut (108) and pull the Coupling Nut Retainer (109) from the Nut. Slide the Coupling Nut and Retainer off the motor end of the Angle Attachment.

Disassembly of the Motor

- Using a No. 2 tip Phillips head screwdriver on the Housing Screws (2) and a No. 1 Phillips head screwdriver on the Coupling Screws (81), remove the two Coupling Screws and the three Housing Screws.

NOTICE

The screw threads are coated with Threadlocker 222. It may be necessary to rapidly tap the end of the screwdriver handle with a hammer while backing the Screws out of the Housing.**

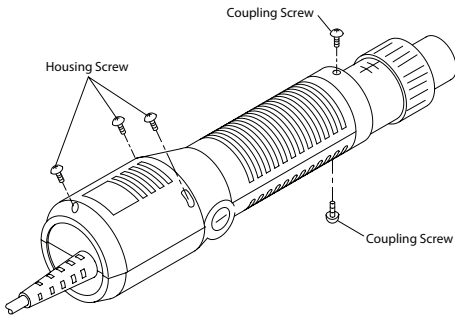

(Dwg. TPD1029)

- Remove the Coupling (80) by pulling it off the front end of the Electric Screwdriver.

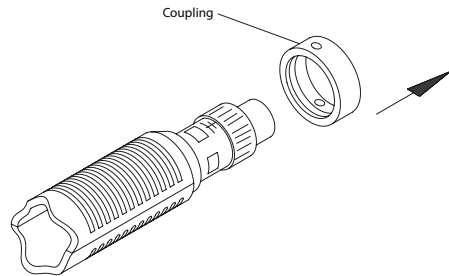

(Dwg. TPD1030)

- Carefully separate the two halves of the Housing (1) by using a thin blade screwdriver to pry them apart.

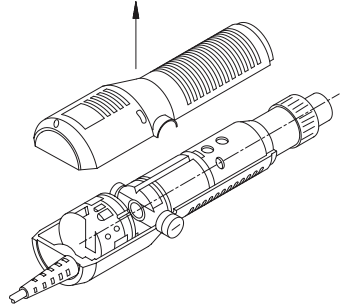

(Dwg. TPD1031)

- With the assembled motor elevated slightly from the Housing, pull the Gear Case Assembly (45) away from the assembled motor.

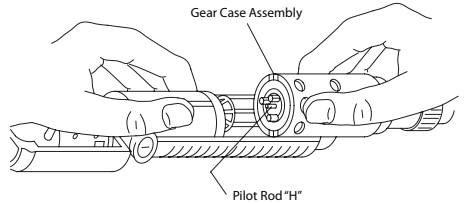

(Dwg. TPD1032)

- Remove the Pilot Rod "H" (59) from the Gear Case Assembly.
- Fit the two notches at the rear of the Gear Case Assembly (45) into an assembly fixture and using an open end wrench on the flats on the Clutch Housing Assembly (78), unscrew and remove the Clutch Housing Assembly.

NOTICE

This is a left-hand thread.

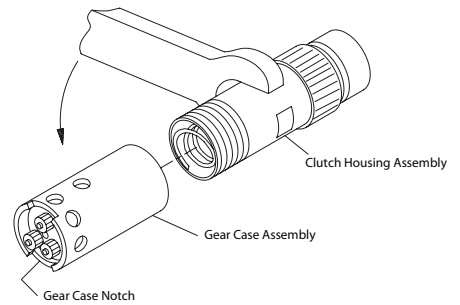

(Dwg. TPD1034)

* Registered trademark of Loctite Corporation.

ES60T Clutch Housing Fixture

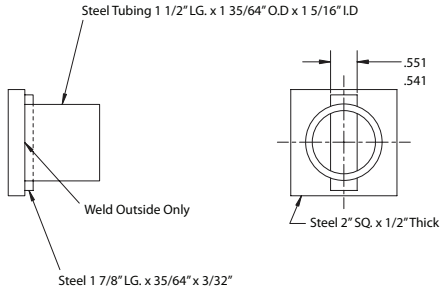

(Dwg. TPD1053)

Removing the Clutch Housing from the Gear Case

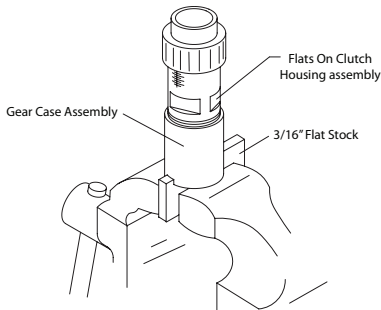

(Dwg. TPD1056)

- Remove the Taper Ring Assembly (63), Cam Guide (60) and Cam Guide Balls (61) from the Gear Case Assembly.

For Model ES100T, remove the Cam (56), Cam Pins (57) and the Cam Washer (58).

For Model ES90T, remove the Cam (54) and Cam Guide Ball (62). Remove the Spindle Assembly (50) and the two Spindle Washers (53) from the Gear Case Assembly.

For all other models, remove the Cam (54). Remove the Spindle Assembly (50), Gear Head Sun Gear (49) and Gear Head Assembly (48) from the Gear Case Assembly. Do not attempt removal of the ring gear inside the Gear Case. It is a press fit into the Gear Case.

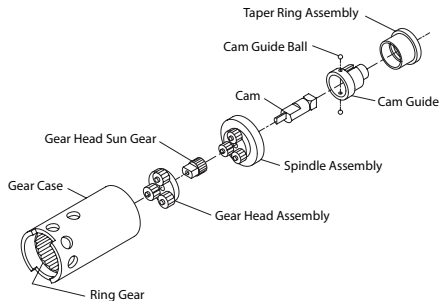

(Dwg. TPD1035)

- Slide the Bit Holder Assembly, Clutch Spring (64), Spring Plate (77) and Holder Bearing Assembly out of the Clutch Housing.

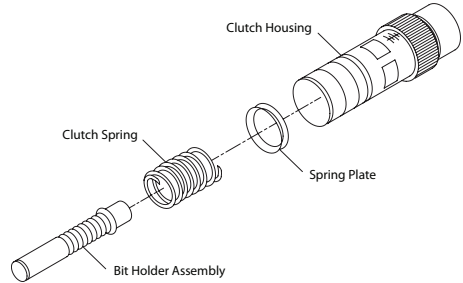

(Dwg. TPD1036)

- Unscrew and remove the Angle Head Coupling (83). Unscrew and remove the Spring Adjusting Ring (82) and pull the three Clutch Adjusting Pins (79) out of the Clutch Housing.

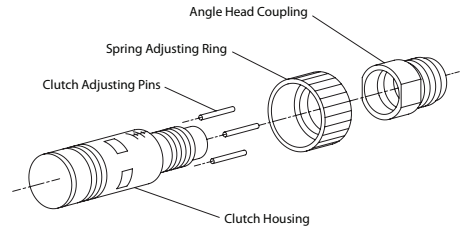

(Dwg. TPD1246)

- Pull the Pilot Rod "H" (59) out of the Bit Holder and using miniature, internal snap ring pliers, remove the Stop Ring (74) from the Bit Holder (65).

NOTICE

Spread the Stop Ring only enough to remove it from the Bit Holder. Excessive expansion may damage the Stop Ring.

- Remove the Washer (73), Slide Ring Spring (72), Slide Ring Washer (71) and Slide Ring (70) from the Bit Holder.

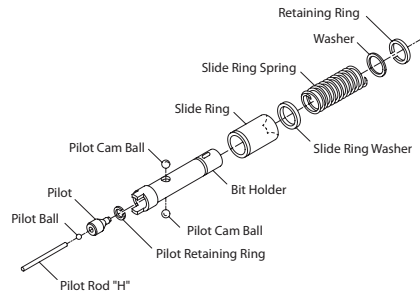

(Dwg. TPD1038)

- When the Slide Ring is removed, the two Pilot Cam Balls (69) will come out of the Bit Holder. Removing the Balls allows the Pilot (66), Pilot Ball (67) and Pilot Retaining Ring (68) to be removed from the end of the Bit Holder.

NOTICE

The Pilot Ball must be clean to be removed from the Pilot. However, only remove the Pilot Ball and Pilot Retaining Ring if it is necessary.

13. Remove the Fan Sun Gear (44) and the Armature Fan (42) from the front of the motor.

NOTICE

Pull the Pilot Rod "G" (43) out of the Fan Sun Gear.



WARNING

Do not lose, substitute or damage Pilot Rod "G". It is a critical component of the tool's electrical insulation system and any substitution, omission or damage could cause a shock.

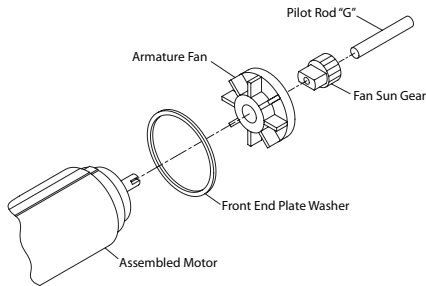

(Dwg. TPD1039)

14. Unscrew and remove the two Brush Caps (32) and pull the two Brush Assemblies (31) out of the Rear End Plate (30). Mark the Brushes so they can be reinstalled exactly as they were removed unless they are replaced.

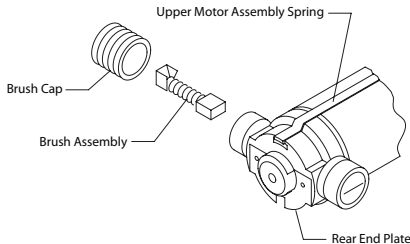

(Dwg. TPD1040-2)

Assembly

To assemble these tools, reverse the disassembly procedure. There are certain assembly and lubrication instructions which are important for optimum performance and they are as follows:

1. Keep the commutator surface of the armature free from all contaminants.
2. Use good quality, properly sized snap ring pliers when installing the Stop Ring (74) on the Bit Holder (65) and do not expand the Stop Ring more than required to install it on the Holder. Excessive expansion may cause the Ring to deform and fail.
3. To assemble the Clutch Housing Assembly (78) to the Gear Case Assembly (49), proceed as follows:
 - a. Apply 0.3 cc of **Ingersoll Rand** No. 67 Grease to the Spindle Assembly (50).
 - b. Insert the Cam (54 or 56), small end first, into the Gear Case.

15. Using a thin blade screwdriver, remove the Motor Assembly Springs (34) by inserting the screwdriver between the Spring and Rear End Plate and prying upward.

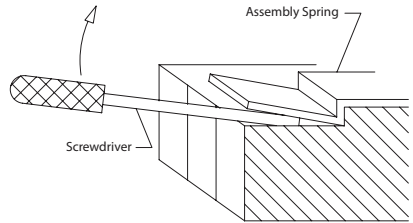

(Dwg. TPD1041)

16. Remove the Rear End Plate (30) and the Front End Plate (39) from the Yoke Assembly (37) and Armature Assembly (36). If Insulators (39A) or Washers (39B) are removed, replace them with new ones.



CAUTION

Do not separate the Armature Assembly from the Yoke Assembly. The magnet in the Yoke will become slightly demagnetized and adversely affect motor performance.

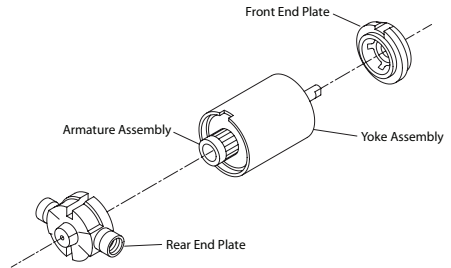

(Dwg. TPD1042)

- c. Inject a small amount of grease into the holes for the Cam Guide Balls (61) and insert a Cam Guide Ball into each hole. **For Model ES100T**, insert a Cam Pin between each of the four Cam Guide Balls and hold each in position with a small amount of grease.
- d. Being careful not to dislodge the Cam Guide Balls or Cam Guide Pins, thread the Gear Case onto the Clutch Housing about two threads.

NOTICE

This is a left-hand thread.

- e. At the middle of the Clutch Housing thread, apply Loctite Threadlocker 242, or equivalent, to approximately three threads.

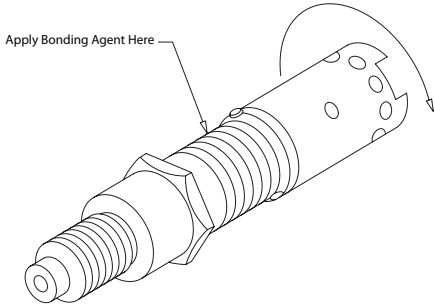

(Dwg. TPD1044)

- f. Carefully thread the Clutch Housing into the Gear Case until contact is made with the Cam. When contact is made, unscrew the Clutch Housing two full thread revolutions.
- g. Insert a 1/4" tee wrench or hex wrench into the end of the Bit Holder (65). While pushing the Bit Holder inward with the wrench, rotate the Gear Case until the jaws of the Cam Guide (60) engage the Cam. The wrench will move inward noticeably when engagement occurs.
- h. While maintaining engagement with the wrench, hand tighten the Gear Case as much as possible.
- i. With the assembly fixture held in vise jaws, position the notches in the Gear Case onto the fixture and, using a torque wrench, tighten the Clutch Housing to 21 ft-lb (28.5 Nm) torque.

NOTICE

Recalibrate the torque wrench every six months.

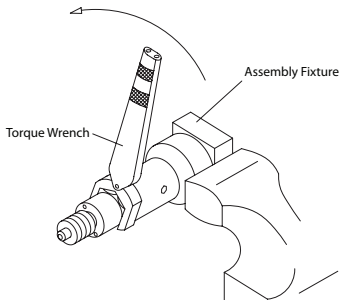

(Dwg. TPD1045)

4. The brake switch must be timed to actuate when the clutch cams over. To adjust the timing, loosen the Adjusting Screw Nut (19) and turn the Adjusting Screw (18) in or out until the microswitch (24) is actuated at the same time the clutch cams over or slightly before it cams over. If the motor lugs before the brake switch actuates, shorten the Adjusting Screw.

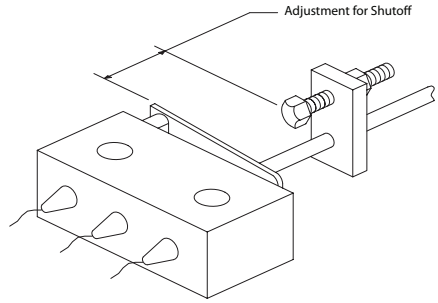

(Dwg. TPD1046)

Assembly of the Angle Attachment

For 3RL23 and 3RL25

1. Apply 2 to 4 cc of **Ingersoll Rand** No. 67 Grease to the gear and onto the shaft of the Bevel Pinion (103) and insert it, gear end first, into the long bore of the Angle Housing (100).
2. Coat the inside of the two Bevel Pinion Bearings (110) with a small amount of **Ingersoll Rand** No. 67 Grease and insert one Bearing, unstamped end first, into the bore of the Angle Housing.
3. Using the bearing inserting tool shown in Dwg. TPD460, press the new Bearing to the "B" dimension shown in Dwg. TPD790.
4. Repeat the process with the second Bevel Pinion Bearing, pressing it to the "C" dimension shown in Dwg. TPD790.
5. Coat the inside of the new Spindle Upper Bearing (102) with a small amount of the recommended grease and coat the outside with a small amount of Loctite® No. 290.

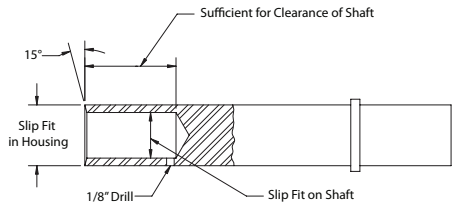

(Dwg. TPD460)

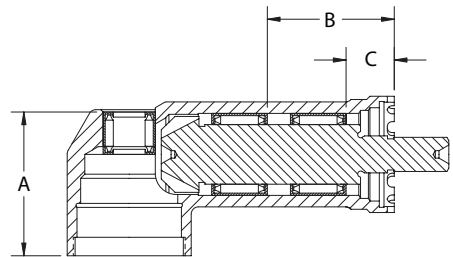

(Dwg. TPD790)

Specifications

Distance	Minimum Dimension		Maximum Dimension	
	in	mm	in	mm
A	1.181	30.0	1.201	30.5
B	1.102	28.0	1.122	28.5
C	0.334	8.5	0.354	9.0

* Registered trademark of Loctite Corporation.

- Install the Front Thrust Bearing Seat (107) on the Bevel Pinion with the beveled side of the seat toward the Pinion Bearings.
- Grease the Bevel Pinion Thrust Bearing (106) and install it against the Seat.
- Install the Rear Thrust Bearing Seat (105) with the flat face against the Thrust Bearing and the radial pin captured by an Angle Housing notch.
- Install the Thrust Bearing Retainer (104) in the groove on the Pinion to lock the components in position. Make certain the Retainer is completely seated in the groove.
- The Socket Retainer (115) for the Square Drive Spindle (114) consists of a plunger, spring and washer. The hole through the square on the working end of the Spindle has an internal shoulder and the hole is deeper on one side of the square than it is on the opposite side. Place the spring into the deeper hole and insert the plunger into the spring until the plunger is flush with the face of the square. Holding the plunger side of the square against a steel block, place the washer, chamfered side away from the plunger, onto the plunger. With a rivet tool, rivet the washer to the plunger.
- Work some grease into the Spindle Lower Bearing and on the Bevel Gear.
- Using a sleeve that will contact only the inner ring of the Bearing, press the Spindle Lower Bearing (112), sealed side first, onto the Spindle.
- Slide the Bevel Gear of the Matched Gear Set (103) onto the Spindle.
- Apply Loctite** Primer Grade T to the threads on the Bevel Gear Retainer Nut (111) and Spindle. Allow to cure for five minutes. Apply Loctite* No. 242 to the threads of the Bevel Gear Retainer Nut and tighten it on the Spindle to 10.3 ft-lb (14 Nm) torque.
- Install the assembled Spindle in the Angle Housing, making certain the teeth of the Matched Gear Set mesh and the Spindle turns freely.
- Clean the threads of the Angle Housing and the Angle Housing Cap (113). Apply a uniform coat of VC3 No. 205 Vibra-Tite*** to the threads of the Angle Housing Cap and allow the compound to cure between ten and twenty minutes. Install the Angle Housing Cap and tighten the Cap to a minimum of 15 to 18 ft-lb (20 to 24 Nm) torque.
- Slide the Coupling Nut Retainer (109) and Coupling Nut (108), threaded end trailing, over the notched end of the Angle Housing.
- Compress the Retainer and work it into the internal groove in the non-threaded end of the Nut.

For 3RL1A5

- Work a light coat of **Ingersoll Rand** No. 67 Grease into the gear teeth of the Bevel Pinion (103) and insert it, gear end first, into the long bore of the Angle Housing (100).
- Work 0.5 to 1 cc of **Ingersoll Rand** No. 67 Grease into the Bevel Pinion Bearing (110) and insert it, unstamped end first, into the bore of the Angle Housing, after the Bevel Pinion.
- Support the Angle Housing on an angled support as shown in Dwg. TPB853 on page 22. Use a bearing inserting tool and press the Bevel Pinion Bearing so the face is a maximum of 1.32" (33.50 mm) but not less than 1.30" (33.00 mm) below the end face of the Angle Head. Refer to Dwg. TPB853.
- Lubricate the Bevel Pinion Thrust Bearing (106) with 0.5 to 1 cc of **Ingersoll Rand** No. 67 Grease. Install the Bearing on the rear of the Bevel Pinion shaft with red-stained end of Bearing toward the rear of the Angle Head. Refer to Dwg. TPA1318 on Page 8. Secure Bearing on shaft with Thrust Bearing Retainer (104).
- The Socket Retainer (103A) consists of a Plunger, Spring and Washer. The hole through the square on the working end of the Spindle has an internal shoulder and the hole is deeper on one side of the square than it is on the opposite side. Place the Spring into the deeper hole and insert the Plunger into the Spring until the Plunger is flush with the face of the square. Holding the Plunger side of the square against a steel block, place the Washer, chamfered side away from the Plunger, onto the Plunger. With a rivet tool, rivet the Washer to the Plunger.

* Registered trademark of Loctite Corporation.

** Registered trademark of ND Industries.

- Apply a small drop of Loctite* No. 601 to the small outside diameter of the spindle upper bearing shaft on the Spindle (103).
- Apply 2 to 4 cc of **Ingersoll Rand** No. 67 Grease to the Spindle Upper Bearing (102) and a light coat of **Ingersoll Rand** No. 67 Grease to the gear teeth on the Spindle. Press the Spindle Upper Bearing onto the Spindle and allow the Loctite to dry a minimum of ten minutes.

NOTICE

Do not get any Loctite in the bearing; damage to the Bearing could result. Do not get any grease on the inside diameter of the Bearing; grease will prevent the Loctite from working.

- Insert the Spindle into the Angle Head until the Spindle Upper Bearing seats into the recess of the Angle Head.

NOTICE

Make sure that the Bevel Pinion is pulled outward toward the Bevel Pinion Bearing before inserting the Spindle into the Angle Head.

- Install the Angle Housing Cap Seal (113B) in the bottom of the Angle Housing Cap (113A).
- Insert the twenty Steel Balls (120) into the Angle Housing Cap and install the Ball Race (119) in the Cap over the Steel Balls.
- Taking care not to tip the Angle Housing Cap, install the Angle Housing Cap finger tight.

NOTICE

Spindle must turn freely.

- With the Bevel Gear on the Spindle out of mesh with the Bevel Pinion, measure the axial play of the Spindle (use .25 lb loads). Subtract .002" (.051 mm) from the reading for required shim thickness. Refer to Dwg. TPB853.
- Unscrew and remove the Angle Housing Cap, again taking care not to lose the Steel Balls from the inside of the Cap. While pulling the Bevel Pinion outward toward the Bevel Pinion Bearing, remove the Spindle from the Angle Head.
- Insert the required number of shims as determined from step 12 in the upper bearing recess of the Angle Head.
- Reassemble and test the Angle Head as indicated in steps 8, 11 and 12.
- Once proper shimming has been achieved, remove the Angle Housing Cap, clean the threads on the Angle Head and the Angle Housing Cap, and apply a film of Vibra-Tite** VC3 to the threads.
- Install the Angle Housing Cap and tighten to 35 in-lb (3.9 Nm) torque.
- Install the Rear Thrust Bearing Seat (105) on the Bevel Pinion shaft with the flat face against the Thrust Bearing.
- Slide the Coupling Nut Retainer (109) and the Coupling Nut (108), threaded end trailing, over the notched end of the Angle Housing.
- Compress the Coupling Nut Retainer, and work it into the internal groove in the nonthreaded end of the Coupling Nut.

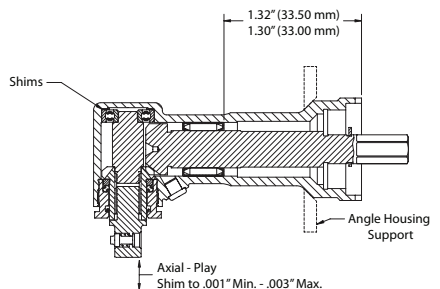

3RL1A5 Angle Attachment

(Dwg. TPD853)

Troubleshooting Guide

Trouble	Probable Cause	Solution
Screwdriver fails to rotate (forward or reverse).	Does the microswitch "click" when the trigger is depressed?	Starting microswitch is defective; replace the microswitch. Pilot Rod "H" is binding; clear obstruction or replace Rod. Pilot Rod "G" or Pilot Rod " H is defective; repair or replace Rod. Incorrect Pilot Rod; check each rod length and place each length in its proper position. Incorrect assembly of Clutch; check clutch parts and balls for proper assembly. Stop Ring out of position; install the Stop Ring Correctly.
	With tool unplugged, can bit be rotated manually?	Defective planetary gearing; replace the defective parts. Defective Clutch; replace the defective parts. Defective Motor; replace the Motor.
	Are the Brush Assemblies in good condition?	Brushes are worn or cracked; replace the Brush Assemblies. Commutator worn; replace the motor,
	Remove the Coupling, separate the Housing halves and plug the tool into an electrical receptacle. Using a voltmeter, make the following determinations:	 WARNING
	Is there voltage to the Motor ?	This procedure has the potential for severe shock hazard and should be performed by qualified personnel. Motor is defective; replace the Motor. Brushes are defective; replace the Brush Assemblies.
	Is there voltage to the Reverse Switch?	Coil is defective; replace the Coil. Wiring is defective; replace any broken wires and resolder any defective solder connections.
	Is there voltage to the Reverse Switch?	Reverse Switch is defective; replace the Reverse Switch. Solder connections are defective; resolder any defective solder connections.
	Is there voltage out of the Power Cord?	Power Cord is defective; replace the Power Cord. Solder connections defective; resolder any defective solder connections.
	Is there voltage to the Controller?	Controller is defective; replace the Controller. Solder connections are defective; resolder any defective solder connections. Replace the On/Off Switch.
Screwdriver operates in one direction but will not operate in the opposite direction.	Are the wire leads in good condition?	Solder connections are defective; resolder any defective solder connections.
	Does the "Forward-Reverse" Switch function properly?	Defective "Forward-Reverse" Switch; replace the Switch.
Bit does not rotate by motor hums?	When the gears removed, will the motor rotate?	Armature is in contact with the magnets; replace the motor. Foreign material in the motor; clean the motor.
	Is the planetary gearing smooth when the bit is rotated by hand?	Bearing has failed; replace the bearing. Gears are worn or damaged; replace any defective gearing. Damaged Gear head Seat or Seat Retainer; replace damaged component. Clutch Assembly is worn; replace damaged or worn parts.
Motor runs but the Bit fails to rotate.	Motor runs but the Bit fails to rotate.	Armature Fan is defective; replace the Armature Fan. Gears are worn or damaged; replace any defective gearing.

Trouble	Probable Cause	Solution
Shut-off Brake malfunctions more than one index of the Clutch.	Does Bit Speed exceed rated speed by more than 100 rpm?	Motor magnet is demagnetized; replace the motor.
	Is Shut-off Brake microswitch functioning? (Does it click when button is depressed and does it test correctly with an ohmmeter?)	Defective microswitch; replace the microswitch.
	Is the Shut-off Brake Switch in the "ON" position when the Bit Holder is fully depressed?	Pilot Rods "H", "G" and "F" are worn; check Rod length. Replace if necessary, Pilot Rod "D" out of adjustment; readjust with Adjusting Screw. Loose Clutch Housing Assembly; tighten the Clutch Housing Assembly.
	With one lead disconnected, does Resistor (R10) show approximately 20 ohms on a ohmmeter?	Resistor is defective; replace the Resistor. Controller package is defective; replace the Controller. Cam is worn and not providing adequate lift; replace the Cam.
Tool makes abnormal sounds when the motor is running.	Is there looseness at the assembled points.	Screws are loose; tighten all Screws. Clutch Housing is loose; tighten Clutch Housing to proper torque.
	After removing the gear train does the motor sound normal when running?	Armature is in contact with the magnet; replace the motor. Foreign material has gotten into the motor; clean or replace the motor. Ball bearing are defective; replace the motor. Armature is defective; replace the motor.
	Is gear train properly lubricated ?	No grease on the gear train; apply a thin film of the recommended grease. Spindle Bearing has failed; replace the Spindle Assembly. Gears are worn or dirty; clean or replace the gears.
Tool generates abnormal heat when operating.	After removing the gear train, does the tool cool down and motor run normally?	Motor is defective; replace the motor. Planetary gears and the Clutch require lubrication; lubricate the Clutch and gear train with the recommended grease.
Tool outputs low torque.	Is the Clutch Housing Assembly joint tight:	Loose joint between the Gear Case and Clutch Assembly; tighten the joint with a torque wrench to the specified torque. Cam is worn; replace the Cam. Clutch Spring is damaged; replace the Clutch Spring. Cam Guide is damaged; replace the Cam Guide.
Tool outputs high torque.	Is the Shut-off brake functioning properly?	Refer to problem No. 5 to check Shut-off brake malfunctions.
	Is the Clutch properly lubricated?	No lubrication on the Clutch components; lubricate the Clutch with the recommended grease.
	Is there wear on the face of Cam Guide where it contacts the Spindle Assembly?	Cam Guide is worn; replace the Cam Guide. Clutch Spring is damaged; replace the Clutch Spring.
Angle Head gets hot.	Excessive Grease?	Too much grease in Angle Head; clean and inspect the Angle Attachment and gearing parts. Lubricate as instructed.
	Inadequate grease?	Not enough grease in the Angle Head; inject 2 to 4 cc of the recommended grease into the Angle Head Grease Fitting.
	Worn or damaged parts?	Worn bevel gearing; inspect the Bevel Gear and Bevel Pinion and replace both parts if either is worn or damaged. They are a matched set and must be replaced together. Worn bearings; inspect all bearings and replace any that are worn or damaged.

Wiring Diagrams

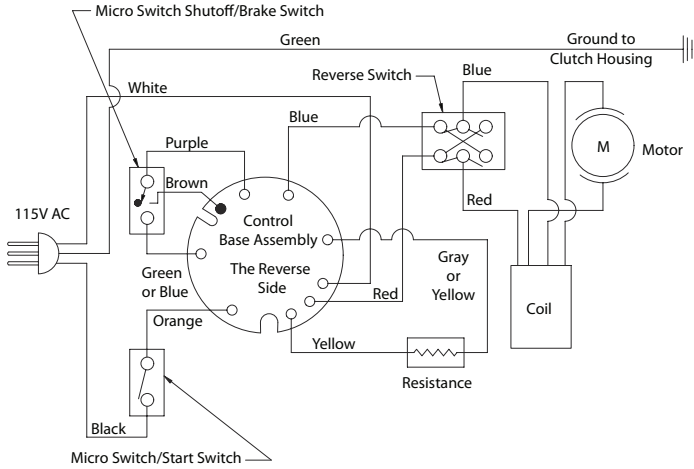

(Dwg. TPD1047-2)

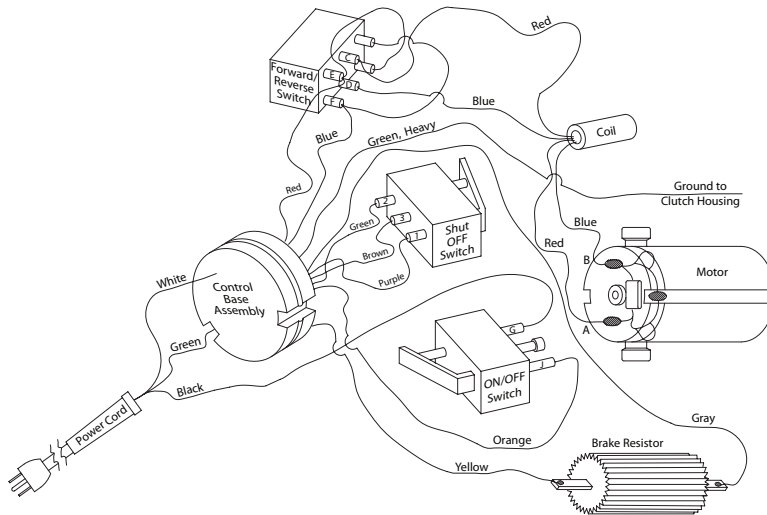

(Dwg. TPD1014-2)

Related Documents

For additional Information Refer to:
 Product Safety Information Manual 16602963.
 Product Information Manual 45527678.
 Parts Information Manual 45527769.

Manuals can be downloaded from www.irttools.com

Notes:

www.irtools.com

© 2008 **Ingersoll Rand** Company

