



45549128
Edition 2
February 2015

Brushless Electric Screwdrivers

**Models ELB2612N, ELB2620N, EPB2612N and
EPB2620N**

Parts Information



Save These Instructions

 **Ingersoll Rand**[®]

Models ELB2612N and ELB2620N Brushless Electric Screwdrivers - Exploded View

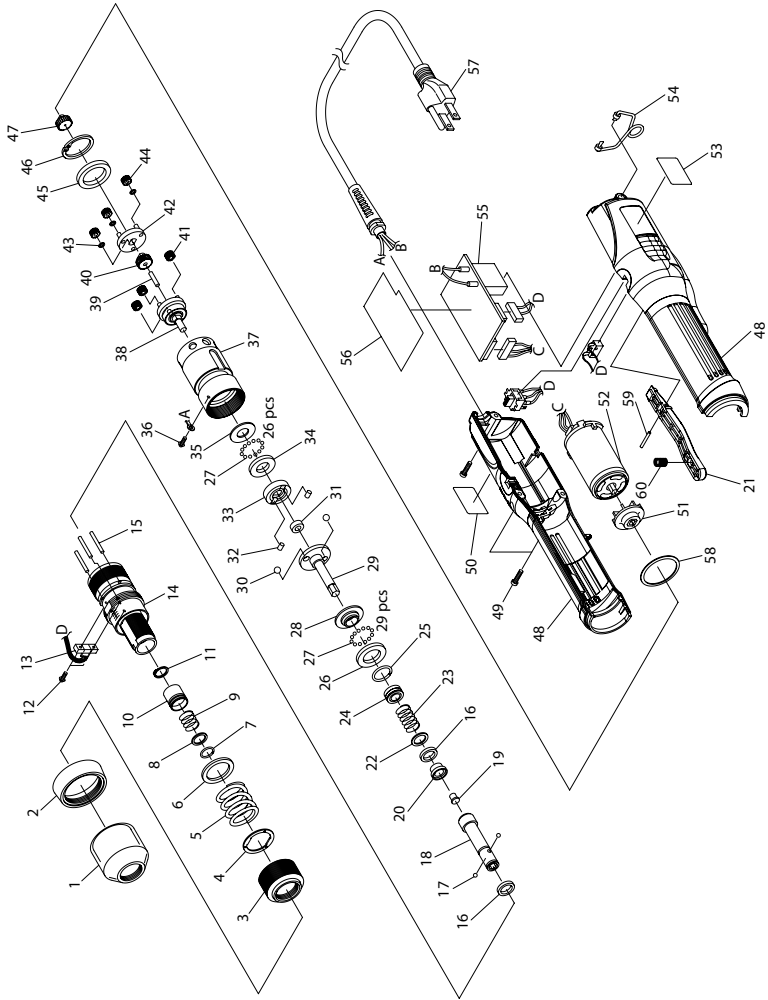

(Dwg. 45574563)

Models ELB2612N and ELB2620N Brushless Electric Screwdrivers - Parts List

Item	Part Description	Part Number	Item	Part Description	Part Number
1	Torque Adjustment Ring Cover	TV05143	34	Thrust Plate	TV04434
2	Coupling (ELB2612N type)	TV05128	35	Washer	TV04540
	Coupling (ELB2620N type)	TV05149	36	Screw M2.6 x 4L	TV00438
3	Torque Adjustment Ring	TV04534	37	Gear Case Assembly (ELB2612N type)	TD05043
4	Bearing Plate Assembly	TD04385		Gear Case Assembly (ELB2620N type)	TD05075
5	Clutch Spring (High Torque Spring)	TV04593	38	Gear Base A Assembly (ELB2612N type)	TD05070
	Clutch Spring (Low Torque Spring F Accessories)	TV05146		Gear Base A Assembly (ELB2620N type)	TD05071
6	Washer	TV05123	39	Roller Pin 3 Dia. x 13.8L	TV04592
7	Stop Ring	TV00149	40	Spindle Gear 19 (ELB2612N type)	TV05125
8	Holder Collar	TV05124		Spindle Gear 23 (ELB2620N type)	TV05258
9	Holder Spring	TV00356	41	Idle Gear 14 (ELB2612N type) (3)	TV05171
10	Holder Clamp	TV05126		Idle Gear 13 (ELB2620N type) (3)	TV05259
11	Stop Ring	LP10494	42	Gear Base B Assembly (ELB2612N type)	TD05110
12	Screw M2.6 x 8L (2)	TV04553		Gear Base B Assembly (ELB2620N type)	TD05111
13	Sensor Assembly	TD05415	43	Spacer (3)	TV00147
14	Clutch Case Assembly	TD05195	44	Idle Gear 17 (ELB2612N type) (3)	TV05172
15	Roller Pin 2.5 Dia. x 21.8L (3)	TV04543		Idle Gear 13 (ELB2620N type) (3)	TV05257
16	Spacer (2)	TV05420	45	Washer	TV04289
17	Steel Ball 2.381 Dia. (2)	CP20000	46	Stop Ring	TV00140
18	Bit Holder	TV05165	47	Motor Gear 13 (ELB2612N type)	TV05132
19	Stopper	TV05256		Motor Gear 23 (ELB2620N type)	TV05260
20	Magnet Plate F	TV04659	48	Frame Handle Assembly	TD05701
21	Lever	TV05378	49	Screw M3 x 12L (3)	TV02746
22	Spacer	TV04545	50	Warning Label	EPB2612N-99
23	Spring	TV04665	51	Fan Assembly	TD05039
24	Brake Magnet Assembly	TD05403	52	Motor Assembly	TD05404
25	Stop Ring	TV04428	53	Model Label (ELB2612N)	ELB2612N-301
26	Thrust Plate F	TV04662		Model Label (ELB2620N)	ELB2620N-301
27	Steel Ball 2 Dia. (55)	TV00121	54	Suspension Bail	TD00585
28	Cam Ring	TV04661	55	Control Base Assembly	TD07585
29	Cam Guide	TV05145	56	Insulated Film	TV05326
30	Steel Ball 5 Dia. (2)	TP15428	57	Power Cord Assembly	TD06627
31	Spacer	TV04751	58	Washer	TV04670
32	Roller Pin 3.5 Dia. x 5L (2)	TV04538	59	Roller Pin 2 Dia. x 15.8L	TQ11207
33	Cam	TV04433	60	Spring	TV00235

Models EPB2612N and EPB2620N Brushless Electric Screwdrivers - Exploded View

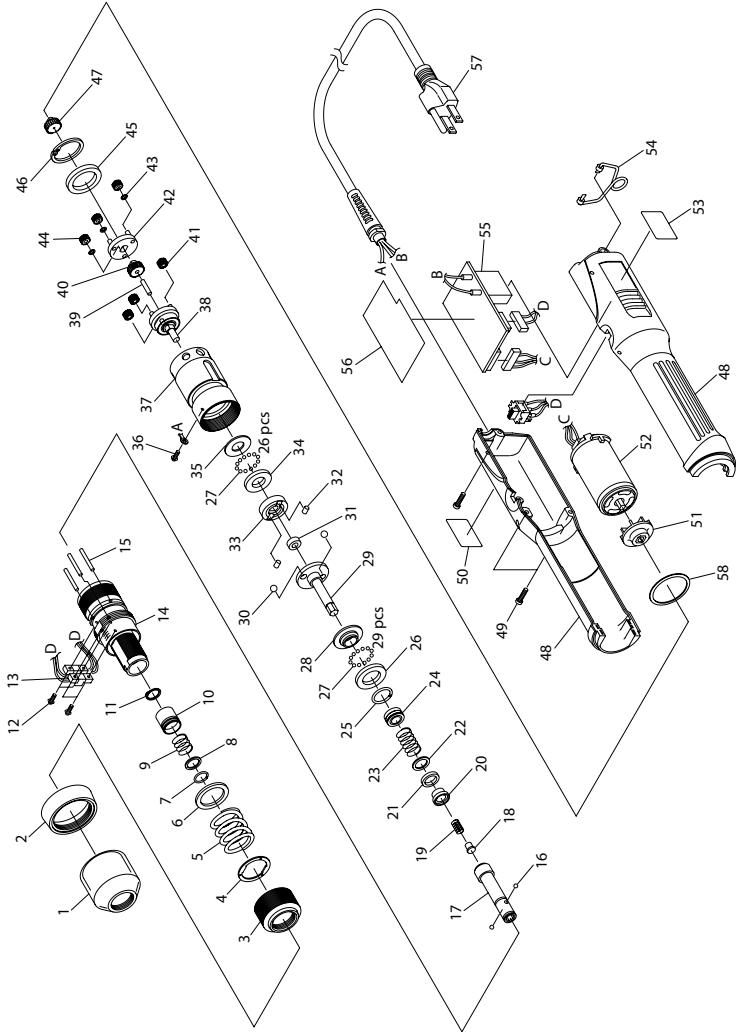

(Dwg. 45574589)

Models EPB2612N and EPB2620N Brushless Electric Screwdrivers - Parts List

Item	Part Description	Part Number	Item	Part Description	Part Number
1	Torque Adjustment Ring Cover	TV05143	33	Cam	TV04433
2	Coupling (EPB2612N type)	TV05128	34	Thrust Plate	TV04434
	Coupling (EPB2620N type)	TV05149	35	Washer	TV04540
3	Torque Adjustment Ring	TV04534	36	Screw M2.6 x 4L	TV00438
4	Bearing Plate Assembly	TD04385	37	Gear Case Assembly (EPB2612N type)	TD05043
5	Clutch Spring (High Torque Spring)	TV04593		Gear Case Assembly (EPB2620N type)	TD05075
	Clutch Spring (Low Torque Spring F Accessories)	TV05146	38	Gear Base A Assembly (EPB2612N type)	TD05070
6	Washer	TV05123		Gear Base A Assembly (EPB2620N type)	TD05071
7	Stop Ring	TV00149	39	Roller Pin 3 Dia. x 13.8L	TV04592
8	Holder Collar	TV05124	40	Spindle Gear 19 (EPB2612N type)	TV05125
9	Holder Spring	TV00356		Spindle Gear 23 (EPB2620N type)	TV05258
10	Holder Clamp	TV05126	41	Idle Gear 14 (EPB2612N type) (3)	TV05171
11	Stop Ring	LP10494		Idle Gear 13 (EPB2620N type) (3)	TV05259
12	Screw M2.6 x 8L (4)	TV04553	42	Gear Base B Assembly (EPB2612N type)	TD05110
13	Sensor Assembly	TD05198		Gear Base B Assembly (EPB2620N type)	TD05111
14	Clutch Case Assembly	TD05195	43	Spacer (3)	TV00147
15	Roller Pin 2.5 Dia. x 21.8L (3)	TV04543	44	Idle Gear 17 (EPB2612N type) (3)	TV05172
16	Steel Ball 2.381 Dia. (2)	CP20000		Idle Gear 13 (EPB2620N type) (3)	TV05257
17	Bit Holder	TV05165	45	Washer	TV04289
18	Stopper	TV05256	46	Stop Ring	TV00140
19	Push Spring	TV05255	47	Motor Gear 13 (EPB2612N type)	TV05132
20	Magnet Plate F	TV04659		Motor Gear 23 (EPB2620N type)	TV05260
21	Magnet	TV04546	48	Frame Handle Assembly	TD05700
22	Spacer	TV04545	49	Screw M3 x 12L (3)	TV02746
23	Spring	TV04665	50	Warning Label	EPB2612N-99
24	Brake Magnet Assembly	TD05403	51	Fan Assembly	TD05039
25	Stop Ring	TV04428	52	Motor Assembly	TD05404
26	Thrust Plate F	TV04662	53	Model Label (EPB2612N)	EPB2612N-301
27	Steel Ball 2 Dia. (55)	TV00121		Model Label (EPB2620N)	EPB2620N-301
28	Cam Ring	TV04661	54	Suspension Bail	TD00585
29	Cam Guide	TV05145	55	Control Base Assembly	TD07585
30	Steel Ball 5 Dia. (2)	TP15428	56	Insulated Film	TV05326
31	Spacer	TV04751	57	Power Cord Assembly	TD06627
32	Roller Pin 3.5 Dia. x 5L (2)	TV04538	58	Washer	TV04670

Parts and Maintenance

When tool life has expired, it is recommended that the tool be disassembled, degreased and parts separated by material for proper recycling.

Tool repair and maintenance should only be carried out by an authorized Service Center.

Refer all communications to the nearest **Ingersoll Rand** office or distributor.

Related Documentation

Manuals can be downloaded from ingersollrandproducts.com

For additional information, refer to:

Product Safety Information Manual 16602963.

Product Information Manual 45549110.

Maintenance Information Manual 45549136.

Notes:

Notes:

ingersollrandproducts.com

© 2015 Ingersoll Rand

