



16601023
Edition 2
January 2014

Air Impact Wrench

2705P1

Maintenance Information



Save These Instructions

IR *Ingersoll Rand*

Product Safety Information

WARNING

- Failure to observe the following warnings, and to avoid these potentially hazardous situations, could result in death or serious injury.
- Read and understand this and all other supplied manuals before installing, operating, repairing, maintaining, changing accessories on, or working near this product.
- Always wear eye protection when operating or performing maintenance on this tool. The grade of protection required should be assessed for each use and may include impact-resistant glasses with side shields, goggles, or a full face shield over those glasses.
- Always turn off the air supply, bleed the air pressure and disconnect the air supply hose when not in use, before installing, removing or adjusting any accessory on this tool, or before performing any maintenance on this tool or any accessory.

Note: When reading the instructions, refer to exploded diagrams in Parts Information Manuals when applicable (see under Related Documentation for form numbers).

Lubrication

Each time a Series 2705P1 Impact Wrench is disassembled for maintenance and repair or replacement of parts, lubricate the tool as follows:

1. Work approximately 4 to 6 cc of **Ingersoll Rand** No. 100 Grease into the impact mechanism. Coat the Anvil (43) lightly with grease around the Hammer Case Bushing (40). Inject approximately 1 to 2 cc of grease into the Grease Fitting (2).

2. Use **Ingersoll Rand** No. 50 Oil for lubricating the motor. Inject approximately 1 to 2 cc of oil into the air inlet before attaching the air hose.
-

Disassembly

General Instructions

1. Do not disassemble the tool any further than necessary to replace or repair damaged parts.
2. When grasping a tool or part in a vise, always use leather-covered or copper-covered vise jaws to protect the surface of the part or tool and help prevent distortion. This is particularly true of threaded members and housings.
3. Do not remove any part which is a press fit in or on a subassembly unless the removal of that part is necessary for repairs or replacement.
4. Do not disassemble the tool unless you have a complete set of new gaskets and O-rings for replacement.

Disassembly of the Impact Wrench

1. Clamp the handle of the Impact Wrench in a vise with the square driver upward.
2. Unscrew and remove the three Hammer Case Cap Screws (41).
3. While lightly tapping on the end of the Anvil (43) with a plastic hammer, lift off the Hammer Case (38).
4. Grasp the Hammer Frame (34) and carefully lift off the entire impact mechanism, making certain not to drop the two Hammer Pins (35). If it is necessary to disassemble the impact mechanism, refer to **Disassembly of the Impact Mechanism**. If it is unnecessary to disassemble the impact mechanism, set it aside intact.

Disassembly of the Impact Mechanism

1. Set the mechanism, driver end up, on the workbench.

NOTICE

Note the twin Hammers (37) within the Hammer Frame. These are identical but must be placed in the Hammer Frame in a certain relationship. Using a felt-tipped pen, mark the top hammer "T" and the bottom hammer "B" with the arrows pointing upward. Mark both Hammers on the same end.

2. With the mechanism sitting upright on the workbench, slowly rotate the Anvil in a clockwise direction until it comes up solid.

NOTICE

If you continue to rotate the Anvil, it will cam the Hammers out of engagement. Don't do this; merely rotate the Anvil until it comes up solid.

3. Hold the Hammer Frame firmly and, without disturbing the hammers, gently lift the Anvil, simultaneously rotating it clockwise about 1/8 of a turn, from the Hammer Frame.

NOTICE

The twin hammers will be free to slide from the Hammer Frame when the Hammer Pins are removed. Do not drop the Hammers.

4. With the Anvil removed, lift out the two Hammer Pins.
5. Remove the Hammers.

Disassembly of the Reverse Valve

1. Unscrew the Reverse Valve Knob Screw (16) and remove the Reverse Valve Knob (15).

NOTICE

This Screw is installed with a thread locking compound. You may have to heat it slightly to loosen the Screw.

2. While slowly rotating the Reverse Valve (12), withdraw it from the Reverse Valve Bushing (3).

NOTICE

Be careful you do not lose the Reverse Valve Detent Ball (13) and Spring (14) from the hole in the side of the Reverse Valve.

Disassembly of the Motor

1. Lift the Rear Hammer Frame Washer (36) and the two Motor Clamp Washers (33) from the front of the motor.
2. Grasp the splined end of the Rotor (22) and pull the assembled motor from the Motor Housing (1).
3. Lift the Front End Plate (30) and Front Rotor Bearing (24) from the splined end of the Rotor.
4. Remove the Cylinder (26) and Vanes (29).
5. Remove the Rear Rotor Bearing Retainer (25).
6. Lift the Rear End Plate (31) and Rear Rotor Bearing (23) from the Rotor.

Disassembly of the Throttle Mechanism

1. Unscrew the Air Strainer (9) and remove it.
2. Withdraw the Throttle Valve Spring (7), Throttle Valve (5), and Throttle Valve Stem (8). Remove the Throttle Valve Face (6) from the Throttle Valve.
3. Remove the Trigger Pin (11) and Trigger (10).

Assembly

General Instructions

1. Always press on the **inner** ring of a ball-type bearing when installing the bearing on a shaft.
2. Always press on the **outer** ring of a ball-type bearing when pressing the bearing into a bearing recess.
3. Whenever grasping a tool or part in a vise, always use leather-covered or copper-covered vise jaws. Take extra care with threaded parts or housings.
4. Always clean every part and wipe every part with a thin film of oil before installation.
5. Apply a film of O-ring lubricant to all O-rings before final assembly.

Assembly of the Throttle Mechanism

1. Place the Trigger (10) in the Housing (1) and secure it with the Trigger Pin (11).
2. Install the Throttle Valve Face (6) on the Throttle Valve (5).
3. Install the Throttle Valve stem (8), Throttle Valve and Throttle Valve Spring (7).
4. Install the Air Strainer Assembly (9) and tighten it to 30 to 35 ft-lb (40.5 to 47.5 Nm) torque.

Assembly of the Motor

1. Using a sleeve that will contact only the outer ring of the bearing, press the Front Rotor Bearing (24) into the Front End Plate (30) and the Rear Rotor Bearing (23) into the Rear End Plate (31).
2. Slip the Front End Plate and Bearing over the splined hub of the Rotor (22).
3. Grasp the splined hub of the Rotor in leather-covered or copper-covered vise jaws so that the Rotor is in a vertical position.
4. Dampen each Vane (29) with light oil and insert a Vane into each vane slot.
5. Set the Cylinder (26) over the Rotor and onto the Front End Plate.
6. Slide the Rear End Plate and Bearing onto the rotor hub and against the Cylinder.
7. Install the Rear Rotor Bearing Retainer (25) in the groove on the rotor hub.
8. Align the dowel hole in both End Plates with the one through the Cylinder, and insert a guide rod 5/32" diameter x 6" long (3.9 mm diameter x 152 mm long). Allow the rod to protrude from the Rear End Plate.
9. Grasp the handle of the Motor Housing in leather-covered or copper-covered vise jaws so that the bore of the Motor Housing is horizontal.
10. Wipe a thin film of light grease on the End Plate Gasket (32) and press the Gasket firmly against the Rear End Plate.
11. Insert the protruding end of the guide rod into the dowel hole in the bore of the Motor Housing, and slide the motor along the rod until it is completely seated.
12. Remove the guide rod and replace it with the Cylinder Dowel (27).
13. Reposition the Motor Housing in the vise so that the open face of the Motor Housing is upward.
14. Place the two Motor Clamp Washers (33), **convex side first**, against the Front End Plate so that the inner rim of the leading Washer contacts the End Plate and the outer rim of the trailing Washer contacts the Hammer Case Pilot (38A).
15. Place the Rear Hammer Frame Washer (36) over the hub of the Rotor and against the Front Rotor Bearing.

Assembly of the Reverse Valve

1. Make certain the Reverse Valve Bushing Seals (4) are properly located in the undercuts in the Reverse Valve Bushing (3).
2. Dampen the Reverse Valve (12) with light oil. Install the Reverse Valve Detent Spring (14) followed by the Reverse Valve Detent Ball (13) in the hole in the Reverse Valve. With the Impact Wrench in an upright horizontal position, and while facing the handle end of the Impact Wrench, slowly rotate the Reverse Valve and insert it from left to right in the splined end of the Reverse Valve Bushing.

3. Apply a thread locking compound to the Reverse Valve Knob Screw (16). Attach the Reverse Valve Knob (15) to the Reverse Valve with the Reverse Valve Knob Screw, and tighten the Screw to 40 to 50 in-lb (4.5 to 5.6 Nm) torque.

Assembly of the Impact Mechanism

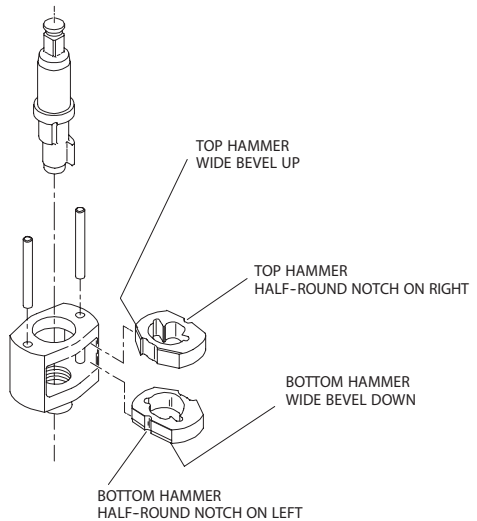

(Dwg. TPD652)

1. Coat the Hammers (37) with a light film of **Ingersoll Rand** Impact Wrench Grease No. 100.
2. Replace the Hammers in the Hammer Frame (34) exactly as they were when you marked them prior to disassembly.

NOTICE

If you are installing new Hammers, or want to change the location of the existing Hammers to utilize both impacting surfaces, slide the Hammers in the Hammer Frame so that the half-round notch on one Hammer is located on one side of the Frame and the half-round notch on the other Hammer is located on the other side of the Frame.

3. Replace the Hammer Pins (35).
4. Examine the base of the Anvil (43) and note its contour. While looking down through the Hammer Frame, swing the top Hammer to its full extreme one way or another until you can match the contour of the Anvil. Enter the Anvil into the Hammer Frame and through the first Hammer. Swing the bottom Hammer in the opposite direction from the top Hammer and maneuver the Anvil slightly until it drops into the bottom Hammer.

Assembly of the Impact Wrench

1. Set the assembled impact mechanism down over the splined hub of the Rotor.
2. Smear a thin film of **Ingersoll Rand** Impact Wrench Grease No. 100 on the inside surface of the Hammer Case Bushing (40), and place the Hammer Case down over the Anvil and against the Motor Housing.
3. Install the Hammer Case Cap Screws (41). Tighten the Hammer Case Cap Screws to 60 to 70 in-lb (6.8 to 7.9 Nm) torque.

Troubleshooting Guide

Trouble	Probable Cause	Solution
Low power	Dirty Inlet Bushing or Air Strainer Screen and/or Exhaust Silencer.	Using a suitable cleaning solution in a well ventilated area, clean Air Strainer Screen, Inlet Bushing and Exhaust Silencer.
	Worn or broken Vanes.	Replace complete set of Vanes.
	Worn or broken Cylinder and/or scored End Plates.	Examine Cylinder and replace it if it is worn or broken or if bore is scored or wavy. Replace End Plates if they are scored.
	Dirty motor parts.	Disassemble the Tool and clean in a suitable cleaning solution in a well ventilated area. Reassemble the tool as instructed in this manual.
	Improper positioning of Reverse Valve.	Make certain Reverse Valve is fully engaged to left or right.
Motor will not run	Incorrect assembly of motor.	Disassemble motor, replace worn or broken parts and reassemble as instructed.
	Insufficient lubrication impact mechanism.	Remove Hammer Case Assembly and lubricate impact mechanism.
Tool will not impact	Broken or worn impact mechanism parts.	Remove Hammer Case Assembly and examine impact mechanism parts. Replace any worn or broken parts.
	Impact mechanism assembled incorrectly.	Refer to Assembly of Impact Mechanism .

Related Documentation

For additional information refer to:
Product Safety Information Manual 04580916.
Product Information Manual 04578183.
Parts Information Manual 16601015.

Manuals can be downloaded from ingersollrandproducts.com

Notes:

Notes:

Notes:

ingersollrandproducts.com

© 2014 *Ingersoll Rand*

