

261 and 271 Series Air Impact Wrench - Exploded View

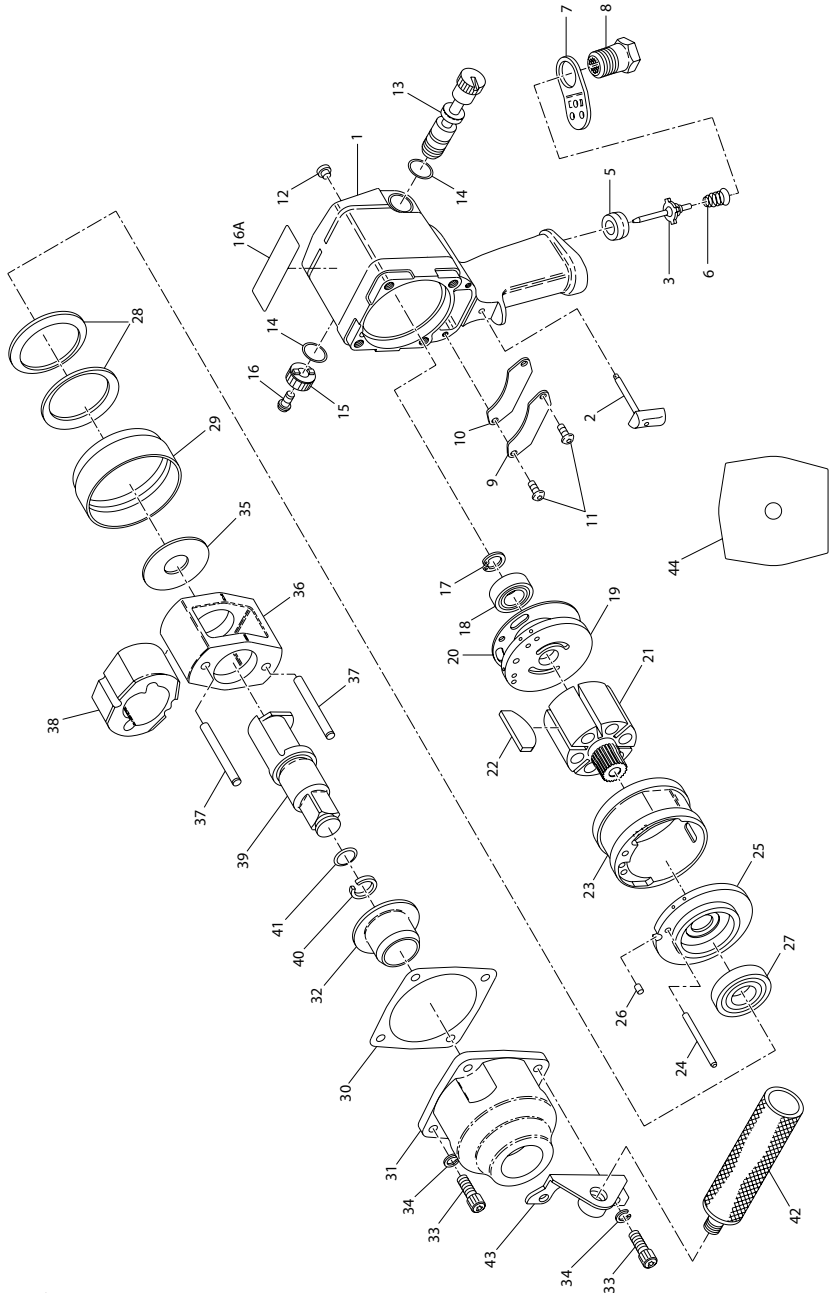

(Dwg. TPA972-2)



261 and 271 Series Air Impact Wrench - Parts List

Item	Part Description	Part Number	Item	Part Description	Part Number
1	Motor Housing Assembly	261-A40	30	Hammer Case Gasket	910-36
2	Trigger Assembly	2920P-A93	31	Hammer Case Assembly	261B-A727
3	Throttle Valve	2921-302	32	Hammer Case Bushing	2920-641
5	Throttle Valve Seat	DG230-303	33	Hammer Case Cap Screw (4)	34U-103
6	Throttle Valve Spring	1720P-51	34	Cap Screw Lock Washer (4)	34U-58
7	Exhaust Deflector	1720P-23	35	Rear Hammer Frame Washer	910-706
8	Inlet Bushing	2920P-465	36	Hammer Frame Assembly	2910-A703
9	Housing Plate	1720P-230	37	Hammer Pin (2)	2910-704
10	Housing Plate Gasket	1720P-231	38	Hammer	260-724
11	Housing Plate Screw (2)	FEA100-112	39	Anvil Assembly	
12	Grease Fitting	130SR-188		3/4" (for 261)	1710-A626A
13	Reverse Valve	1710B-329		3/4" extended (for 261-3)	261-A626-3
14	Reverse Valve Seal (2)	261-283		3/4" extended (for 261-6)	265-A626-6
15	Reverse Valve Knob	231-666		1" (for 271)	275-A626
16	Reverse Valve Knob Screw	231-665	40	Socket Retainer	
16A	Warning Label	WARNING-2-99		3/4" (for 261, 261-3 and 261-6)	908B5-918
17	Rotor Bearing Retainer	MVA008-218		1" (for 271)	910E5-918
18	Rear Rotor Bearing	4E-510	41	Socket Retainer O-ring	
19	Rear End Plate	2921HP-12		3/4" (for 261, 261-3 and 261-6)	AF120-289
20	Rear End Plate Gasket	2920B-283		1" (for 271)	BBFM-557
21	Rotor	2910B-53	42	Handle (for 271)	834-48
22	Vane Packet (set of 6 Vanes)	2910-42-6	43	Bracket (for 271)	2910B-364
23	Cylinder	2920-3	44	Nameplate	
24	Cylinder Dowel	910-98		for 261, 261-3 and 261-6	261-301
25	Front End Plate	2921HP-11		for 271	271-301
26	End Plate Dowel	2920-74	*	Horizontal Hanger	910-366
27	Front Rotor Bearing	834-24	*	Housing Boot	261-P32
28	Motor Clamp Washer (2)	2920-207	*	Tune-up Kit (includes illustrated parts, 3, 5, 6, 10, 14[2], 17, 18, 20, 22, 27, 30, 40 and 41)	261-TK2
29	Motor Retainer	2920B-800			

* Not illustrated.

Parts and Maintenance

When the life of the tool has expired, it is recommended that the tool be disassembled, degreased and parts be separated by material so that they can be recycled.

Tool repair and maintenance should only be carried out by an authorized Service Center.

Refer all communications to the nearest **Ingersoll Rand** Office or Distributor.

Related Documentation

For additional information refer to:

Air Impact Wrench Product Safety Information Manual 04580916.

Air Impact Wrench Product Information Manual 04584744.

Manuals can be downloaded from ingersollrandproducts.com

