



45654530

Edition 6

April 2023

Air Grinders

344MAX, 345MAX and 3445MAX Series

Parts Information



Save These Instructions



344MAX, 345MAX and 3445MAX Series, Air Grinder - Exploded View

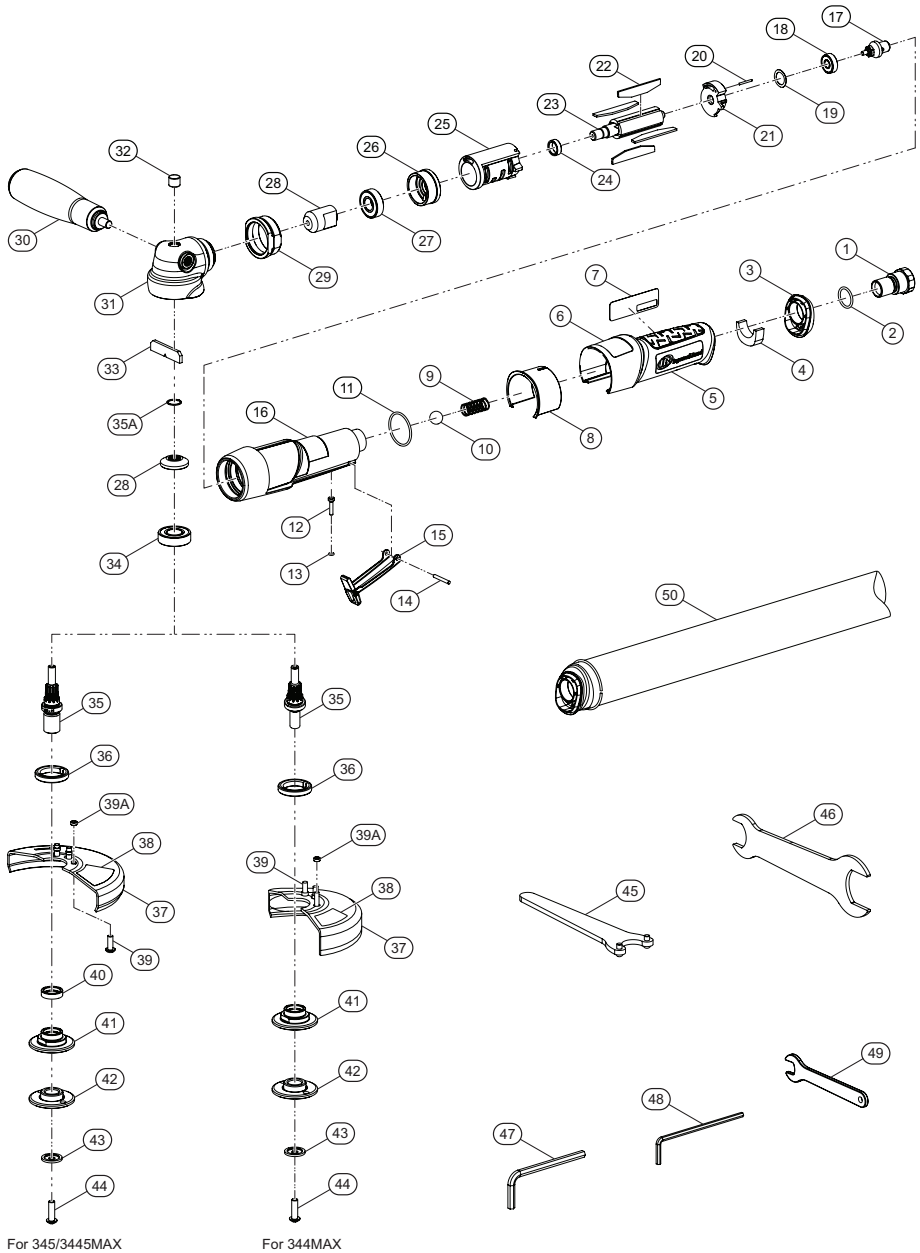

(Dwg. 45664240)

344MAX, 345MAX and 3445MAX Series, Air Grinder - Parts List

Item	Part Description	Part Number (CCN)	Item	Part Description	Part Number (CCN)
1	Inlet Bushing Assembly	MG1-A465 (45613908)	36	Bearing Retainer	MG1-531 (16611295)
*	Inlet Bushing	---	37	Wheel Guard Assembly	
*	Inlet Screen	R1602-61 (03471521)		for 344MAX	MG1-A106-4 (47800660001)
2	Inlet Seal	(45635141)		for 345MAX and 345MAX-M	MG1-A106-5 (45667532)
3	Rear Exhaust Diffuser	MG1-123 (45621232)		for 3445MAX and 3445MAX-M	MG1-A106-45 (45667524)
4	Rear Exhaust Diffuser Muffler	MG1-311 (45626751)		Wheel Guard	---
5	Housing Sleeve Assembly	MG1-A747 (45667516)	38	Guard Warning Label	MG1-99G (45655933)
6	Warning Label	MG1-99 (45625746)	39	Guard Mounting Screw (3 required)	(16610875)
7	Model Label			39A	Guard Screw Retaining Grommet (3 required)
	for 344MAX	344MAX-300 (47810494001)			
	for 345MAX	345MAX-300 (45625738)			
	for 345MAX-M	345MAX-M-300 (45625720)			
	for 3445MAX	3445MAX-300 (45625704)	40	Wheel Spacer (For use with thread on wheels)	
	for 3445MAX-M	3445MAX-M-300 (45625712)		for 344MAX	---
8	Housing Sleeve Trim	MG1-747T1 (45621224)		for 345MAX and 345MAX-M	MG1-339 (45635091)
				for 345MAX and 3445MAX-M	
9	Ball Valve Spring	MG1-51 (45635687)	41	Wheel Flange	
10	Ball	D10-280 (03176864)		for 344MAX	MG1-337-4 (47797588001)
11	Motor Housing O-Ring	(45631025)		for 345MAX and 3445MAX	MG1-337 (16611337)
12	Throttle Pin	MG1-161 (45622644)		for 345MAX-M and 3445MAX-M	MG1-337M (45642964)
13	Throttle Pin O-Ring	(45635125)	42	Flange Nut	
14	Lever Pin	RG1-120 (45727955)		for 344MAX	MG1-338-4 (47797589001)
15	Lever Assembly	RG1-A400 (45756103)		for 345MAX and 3445MAX	MG1-338 (16610784)
	Lever	---	for 345MAX-M and 3445MAX-M	MG1-338M (16611410)	
	Lock Spring	---	43	Wheel Retaining Screw Washer	
	Lock Pin	---		for 344MAX	12A5C24 (95234456)
	Lever Lock	---		for 345MAX and 345MAX-M	LG2-218 (04285169)
			for 3445MAX and 3445MAX-M		
16	Motor Housing Assembly	MG1-A40 (45644564)	44	Wheel Retaining Screw	
	Motor Housing	---		for 344MAX	MG1-219-4 (47797931001)
*	Throttle Bushing	---		for 345MAX and 345MAX-M	LG2-219M (04285151)
*	Ball Valve Seat	---	for 3445MAX and 3445MAX-M		
17	Controller Assembly	MG1-A424 (16611840)	45	Flange Nut Wrench	
18	Rear Rotor Bearing	MG1-127 (45624905)		for 344MAX	MG1-26-4 (47797933001)
19	Wave Spring	GS25-250 (45518537)		for 345MAX and 345MAX-M	AG3-26M (80172448)
20	Roll Pin	(45626959)		for 3445MAX and 3445MAX-M	
21	Rear End Plate	MG1-12 (45620432)	46	Clamp Nut and Wheel Flange Wrench	
22	Vane Pack (set of 4)	MG1-42-4 (45664372)		for 344MAX	MG1-253-4 (47798150001)
23	Rotor	MG1-53-4 (45618816)		for 345MAX and 345MAX-M	MG1-253 (45638830)
24	Motor Spacer	MG1-65 (45621372)	for 3445MAX and 3445MAX-M		
25	Cylinder	MG1-3 (45615523)	47	Arbor Wrench	
26	Front End Plate	MG1-11 (45615986)		for 344MAX	MG1-340-4 (47798148001)
27	Front Rotor Bearing	MG1-24 (45624418)		for 345MAX and 345MAX-M	AG230-340M (03805769)
28	Bevel Pinion and Bevel Gear Set	LA2-A552-1.3 (03920899)		for 3445MAX and 3445MAX-M	
29	Clamp Nut	MG1-27 (45616000)	48	Wheel Retaining Screw Wrench	
30	Handle	MG1-48 (45640356)		for 344MAX	(47798149001)
31	Angle Housing Assembly	MG1-A550 (45647047)		for 345MAX and 345MAX-M	AG2-562 (45620069)
	Angle Housing	---		for 3445MAX and 3445MAX-M	
32	Needle Bearing	MG1-693 (45635646)	49	Controller Wrench	112915 (04381117)
*	Grease Fitting	DOF9-879 (03123999)		50	Piped Away Exhaust Assembly
33	Wick	LA2-561 (03937943)	Piped Away Exhaust Adapter		---
34	Arbor Bearing	MG1-593 (45627981)	Piped Away Exhaust Hose		---
35	Arbor		Exhaust Hose Retaining Ring		---
	for 344MAX	MG1-4-4 (47797590001)	Piped Away Exhaust Inlet Bushing Assembly	---	
	for 345MAX and 3445MAX	MG1-4 (16611386)			
	for 345MAX-M and 3445MAX-M	MG1-4M (16611345)			
35A	Retaining Ring	(45669389)			

* Indicates not illustrated.

Parts and Maintenance

When tool life has expired, it is recommended that the tool be disassembled, degreased and parts separated by material for proper recycling.

Tool repair and maintenance should only be carried out by an Authorized Service Center.

Refer all communications to the nearest **Ingersoll Rand** office or distributor.

Related Documentation

Manuals can be downloaded from **ingersollrand.com**

For additional information, refer to:

Product Safety Information Manual 04584959

Product Information Manual 45654522

Declaration of Conformity 47737060001

Notes:

Notes:

Notes:

[ingersollrand.com](https://www.ingersollrand.com)

© 2023 *Ingersoll Rand*

