

# 109XPA and 1099XPA Air Ratchet Wrench - Exploded View

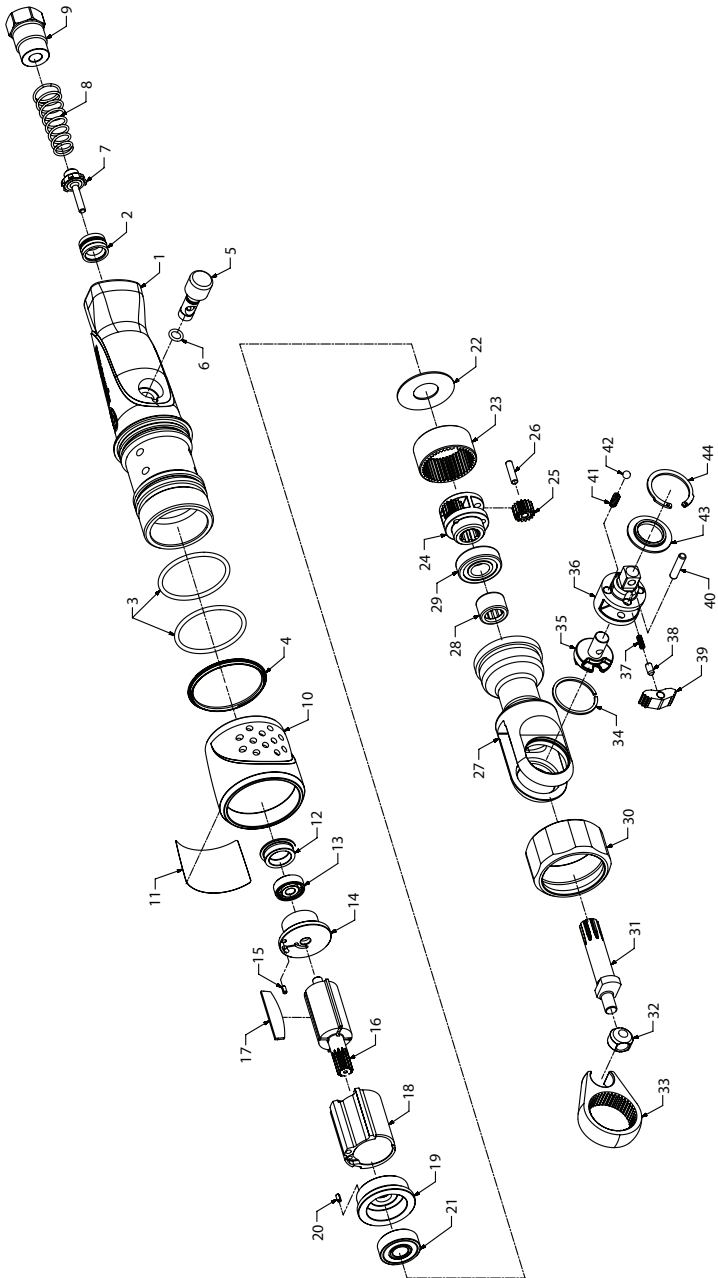

(Dwg. 80195829)



## 109XPA and 1099XPA Air Ratchet Wrench - Parts List

Item	Part Description	Part Number	Item	Part Description	Part Number
	Housing Assembly	109XPA-A40	27	Ratchet Housing	---
1	Housing	---	28	Crankshaft Needle Bearing	---
2	Valve Seat	131-303	29	Crankshaft Ball Bearing	---
3	O-ring (2 per housing assembly)	109XPA-367	30	Coupling Nut	109XPA-27
4	Ring	109XPA-338	31	Crankshaft	109XPA-35
	Throttle Kit	109XPA-TK	32	Drive Bushing	170-36
5	Trigger	---	33	Yoke	109XPA-37
6	O-ring	109XPA-158		Ratchet Head Kit	
7	Throttle Valve	131-50		for 109XPA	109XPA-TRK1
8	Throttle Valve Spring	131-51		for 1099XPA	1099XPA-TRK1
9	Inlet Bushing Assembly	109XPA-A565	34	Friction Ring	109XPA-427
	Exhaust Deflector Assembly		35	Reverse Button	109XPA-38
	for 109XPA	109XPA-A123	36	Anvil Assembly	
	for 1099XPA	1099XPA-A123		for 109XPA	109XPA-D44
10	Exhaust Deflector	---		for 1099XPA	1099XPA-D44
11	Nameplate / Warning Label			Pawl Kit	109XPA-K43
	for 109XPA	109XPA-301	37	Lock Spring	---
	for 1099XPA	1099XPA-301	38	Lock Pin	---
	Motor Kit	109XPA-MK	39	Pawl	---
12	End Cap	---	40	Pawl Retaining Pin	---
13	Rear Rotor Bearing	170-97		Spring Kit	109XPA-SK
	Rear End Plate Assembly	109XPA-A12	41	Friction Spring (3 per kit)	---
14	Rear End Plate	---	42	Friction Ball (3 per kit)	---
15	Motor Alignment Pin	---	43	Thrust Washer	---
16	Rotor	109XPA-53	44	Retaining Ring	---
17	Vane Pack (set of 4)	109XPA-42-4		Tune-Up Kit (includes items 2, 3, 5 through 8, 12, 13, 17, and 21)	109XPA-TK1
18	Cylinder	109XPA-3		Oil - Ingersoll Rand No. 10 (4 oz. bottle)	10Z4
	Front End Plate Assembly	109XPA-A11		Grease	
19	Front End Plate	---		IR # 67 (1 lb. can) - for Gearing	67-1 LB
20	Motor Alignment Pin	---		IR # 67 (8 lb. can) - for Gearing	67 8 LB
21	Front Rotor Bearing	WFS182-22		IR # 70 (1 lb. can) - for Ratchet Head	70 1 LB
22	Spacer	109XPA-18		IR # 70 (8 lb. can) - for Ratchet Head	70 8 LB
	Gearing Kit	109XPA-GK			
23	Internal Gear	109XPA-406			
24	Spindle	109XPA-8			
25	Planet Gear (3 per gearing kit)	109XPA-9			
26	Planet Gear Pin (3 per gearing kit)	109XPA-524			
	Ratchet Housing Assembly	109XPA-A322			

## Parts and Maintenance

When the life of the tool has expired, it is recommended that the tool be disassembled, degreased and parts be separated by material so that they can be recycled.

Tool repair and maintenance should only be carried out by an authorized Service Center.

Refer all communications to the nearest **Ingersoll Rand** Office or Distributor.

## Related Documentation

For additional information refer to:

Air Ratchet Wrench Product Safety Information Manual 04580361.

Air Ratchet Wrench Product Information Manual 80177645.

Manuals can be downloaded from [ingersollrandproducts.com](http://ingersollrandproducts.com).

