

# 3103XPA Mini Surface Prep Sander Exploded View

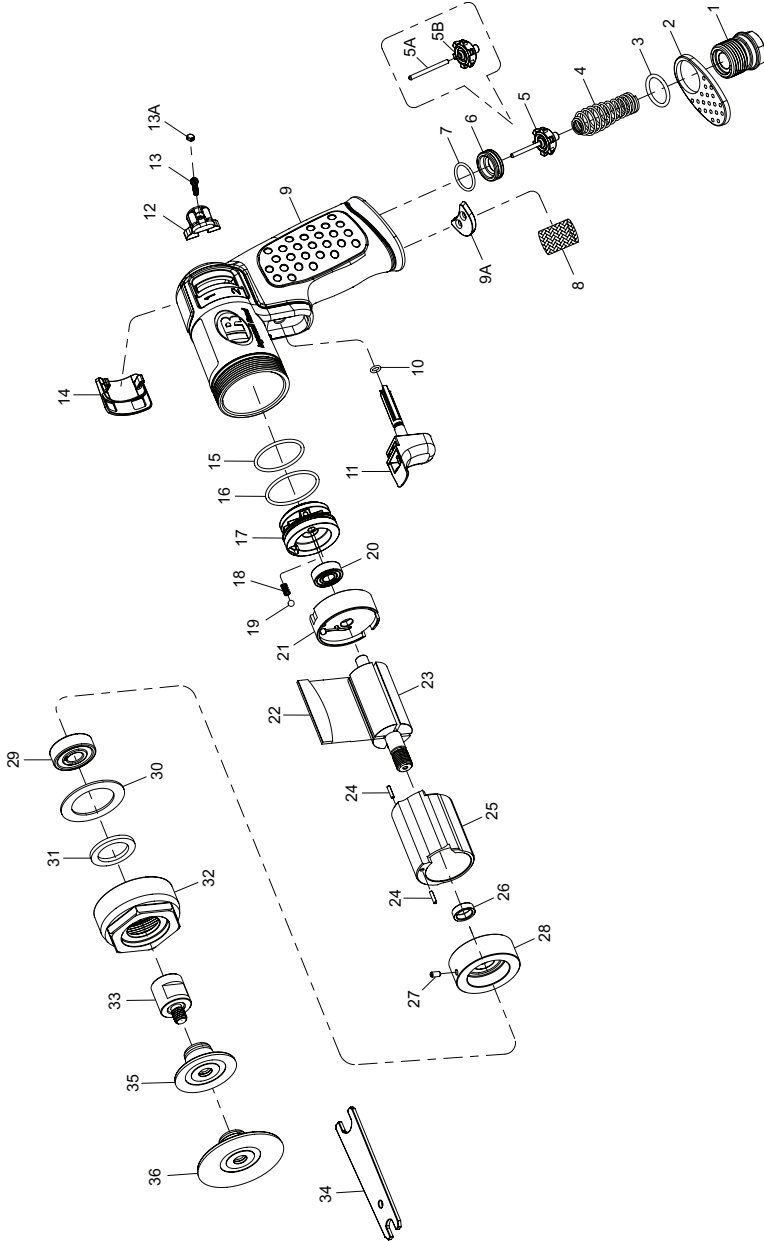

(Dwg. 47520790001)



### 3103XPA Mini Surface Prep Sander Parts List

Item	Part Description	Part Number	(CCN)	Item	Part Description	Part Number	(CCN)
1	Air Inlet with Screen	2101XPA-A465	(47520794001)	15	O-Ring	2101XPA-65C	(47520809001)
2	Exhaust Deflector	2101XPA-23	(47520795001)	16	O-Ring	2101XPA-65D	(47520810001)
3	O-Ring	2101XPA-65	(47520796001)	17	Power Valve	3129XPA-329	(47520909001)
4	Spring	2101XPA-51	(47520797001)	18	Spring	2101XPA-250	(47520812001)
5	Throttle Valve Assembly	2101XPA-A302	(47520798001)	19	Steel Ball	2101XPA-722	(47520813001)
5A	Throttle Valve Pin	--	--	20	Ball Bearing	7804XPA-105	(47520853001)
5B	Throttle Valve	--	--	21	Rear End Plate	3129XPA-12	(47520910001)
6	Throttle Valve Seat	2101XPA-303	(47520799001)	22	Rotor Blade (4)	2101XPA-42-4	(47520868001)
7	O-Ring	2101XPA-65A	(47520800001)	23	Rotor	3128XPA-53	(47520924001)
8	Muffler Element	2101XPA-674	(47520801001)	24	Spring Pin (2)	2101XPA-120-2	(47520818001)
9	Motor Housing Motor Housing Assembly for 3103XPA	3103XPA-A40	(47520768001)	25	Cylinder	3129XPA-3	(47520912001)
9A	Muffler Insert	3128XPA-310	(47520923001)	26	Rotor Collar	3128XPA-80	(47520925001)
	Motor Housing	3129XPA-40	(47520908001)	27	Spring Pin	2101XPA-15	(47520820001)
	Model Label	3103XPA-301	(47512911001)	28	Front End Plate	3128XPA-11	(47520926001)
	Warning Label	3103XPA-99	(47512916001)	29	Ball Bearing	3128XPA-24	(47520927001)
10	O-Ring	2101XPA-65B	(47520803001)	30	Washer	3128XPA-248	(47520928001)
11	Trigger	2101XPA-93	(47520804001)	31	Felt Seal	3128XPA-31	(47520929001)
12	Reverse Knob	2101XPA-329A	(47520805001)	32	Clamp Nut	3128XPA-27	(47520930001)
13	Screw	2101XPA-638	(47520806001)	33	Spindle	3103XPA-109	(47520838001)
13A	Plug	2101XPA-34	(47520807001)	34	Spanner Wrench	3103XPA-253	(47520845001)
14	Reverse Plate	2101XPA-851	(47520808001)	35	2" Pad	02A-MEDPD-NM	(80211915)
				36	3" Pad	03A-MEDPD-NM	(80211923)

### Parts and Maintenance

When tool life has expired, it is recommended that the tool be disassembled, degreased and parts separated by material for proper recycling.

Tool repair and maintenance should only be carried out by an authorized Service Center.

Refer all communications to the nearest **Ingersoll Rand** office or distributor.

### Related Documentation

Manuals can be downloaded from [ingersollrandproducts.com](http://ingersollrandproducts.com)

For additional information, refer to:

Product Safety Information Manual 04580387.

Product Information Manual 47520876001.

